



Standard Specifications
June 2026

Table of Contents

- PART 1- GENERAL PROVISIONS 9**
 - SECTION 1- GENERAL GUIDELINES 9**
 - 1-1 Definitions..... 9
 - 1-2 Terms10
 - 1-3 Abbreviations.....10
 - 1-4 Applicability11
 - 1-5 Description of the work.....11
 - SECTION 2 – DESIGN CRITERIA11**
 - 2-1 Preliminary Investigation11
 - 2-2 Sewer System Design Criteria11
 - 2-3 Utility Notification and Potholing.....14
 - 2-4 Testing14
 - 2-5 Plan Preparation15
 - 2-6 Record Drawings.....15
 - 2-7 Easements and Permits.....15
 - 2-8 Plan Approval16
 - SECTION 3 – CONSTRUCTION AND INSPECTION16**
 - 3-1 Governing Specifications.....16
 - 3-2 District Permit16
 - 3-3 Connection to Existing Facilities16
 - 3-4 Notice16
 - 3-5 Other Permits17
 - 3-6 Construction Water.....17
 - 3-7 Inspection17
 - SECTION 4 – CONTROL OF MATERIAL18**
 - 4-1 Quality of Materials.....18
 - 4-2 Defective Materials.....18
 - 4-3 Storage of Materials18
 - SECTION 5 – USE OF COMPLETED PORTIONS18**
 - SECTION 6 – LEGAL RELATIONS AND RESPONSIBILITIES19**
 - 6-1 Observing Laws and Ordinances19

6-2 Permits and Licenses	19
6-3 Inventions, Patents and Copyrights	19
6-4 Public Convenience and Safety	19
6-5 Responsibility for Loss, Damage or Injuries.....	20
6-6 Owner's Responsibility for the Work.....	20
6-7 Preservation of Property	20
6-8 Safety.....	21
6-9 Personal Liability	21
6-10 Indemnity	21
6-11 Warranty of Title.....	22
6-12 Termination for Breach	22
6-13 Notice and Service Thereof	23
SECTION 7 – INSURANCE REQUIREMENTS	23
7-1 General	23
7-2 Workers’ Compensation Insurance	23
7-3 Liability Insurance.....	24
SECTION 8 – CONSTRUCTION SECURITY	25
8-1 General	25
8-2 Performance Bond	25
8-3 Payment Bond	25
8-4 Guarantee Bond.....	25
SECTION 9 – FINAL ACCEPTANCE OF THE WORK BY THE DISTRICT	26
Part 2- TECHNICAL SPECIFICATIONS	26
SECTION 10- EARTHWORK.....	26
10-1 General	26
10-2 Earthwork in State, County, and City Rights-Of-Way.....	26
10-3 Safety Precautions	26
10-4 Bracing Excavations	26
10-5 Open Excavations and Stockpiling	27
10-6 Selected Material for Pipe Bedding and Pipe Zone	27
10-7 Sand	27
10-8 Aggregate for Pipe Bedding Foundation and Pipe Zone.....	27

10-9 Obstructions	28
10-10 Compaction Tests	28
10-11 Correction of Faulty Grades	28
10-12 Clearing and Grubbing.....	29
10-13 Blasting and Explosives.....	29
10-14 Dewatering	29
Section 11- PIPELINE AND TRENCH EARTHWORK.....	30
11-1 General	30
11-2 Excavation For Pipe Trenches	30
11-3 Trench Width.....	30
11-4 Limit Of Excavation	30
11-5 Trench Bottom For Pipe.....	30
11-6 Trench Backfill	31
11-7 Pipe Bedding	31
11-8 Procedure At Pipe Zone.....	31
11-9 Procedure Above Pipe Zone	32
11-10 Compaction In Open Fields.....	32
11-11 Procedure At Street Zone	32
11-12 Excess Excavated Material	33
11-13 Imported Pipe Backfill Material	33
Section 12- STRUCTURES EARTHWORK.....	33
12-1 General	33
12-2 Subbase for Structures	33
12-3 Subbase Materials	34
12-4 Backfilling.....	34
Section 13- VITRIFIED CLAY SEWER PIPE AND FITTINGS	34
13-1 General	34
13-2 Materials	35
13-3 Identification Marks	35
13-4 Causes for Pipe Rejection.....	35
13-5 Fittings.....	35
13-6 Branches	36
13-7 Stoppers.....	36

13-8 VCP At Manholes or Structures	36
13-9 Sanitary “WYE” or “TEE” Branches.....	36
13-10 Installation.....	38
13-11 Test for Leakage and Infiltration.....	38
SECTION 14- POLYVINYL CHLORIDE SEWER PIPE AND FITTINGS	41
14-1 General	41
14-2 Materials	41
14-3 Identification Marks	41
14-4 Cell Classification.....	41
14-5 Test Requirements	42
14-6 Gaskets.....	42
14-7 Fittings.....	42
14-8 Branches	42
14-9 Installation	42
14-10 Testing	43
SECTION 15- CONNECTIONS TO EXISTING SEWER PIPE.....	46
15-1 Temporary Handling of Sewage	46
15-2 Remodeling Existing Manholes.....	46
15-3 Installation and Remodeling of Existing Manholes Along Existing HDPE Outfall Sewer	46
15-4 Datum Verification	47
SECTION 16- SEWER LATERALS.....	47
16-1 General	47
16-2 Materials and Workmanship	47
16-3 Installation of Sewer Laterals.....	47
SECTION 17- CONCRETE CONSTRUCTION	48
17-1 General	48
17-2 Concrete	48
17-3 Concrete Design and Materials	49
17-4 Reinforcing	49
SECTION 18- PRECAST CONCRETE MANHOLES.....	49
18-1 General	49
18-2 Materials and Workmanship	49

SECTION 19- CHEMICAL-RESISTANT COATINGS FOR MANHOLES.....	52
19-1 General	52
19-2 Materials	52
SECTION 20- SEWER CLEANOUTS	52
20-1 General	52
20-2 Construction	52
SECTION 21-TRAFFIC REGULATION	53
21-1 General	53
21-2 Vehicular Traffic	53
21-3 Temporary Steel Plate Bridging, with a Nonskid Surface	53
21-4 Vehicular Traffic Control	54
21-5 Pedestrial Traffic Control	54
21-6 Access To Adjacent Properties	54
SECTION 22- REMOVAL AND RESURFACING OF STREET PAVEMENT AND SURFACES	54
22-1 General	54
22-2 Earthwork.....	54
22-3 Pavement Removal	54
22-4 Resurfacing.....	55
22-5 Temporary Resurfacing	56
SECTION 23- STEEL CASING PIPE	56
23-1 General	56
23-2 Materials	56
23-3 Installation	56
23-4 EARTHWORK AND RESURFACING	56
SECTION 24- USE OF COMPLETED FACILITIES	56
SECTION 25- INSPECTION OF WORK	57
SECTION 26- CLEAN-UP.....	58
SECTION 27- GENERAL REQUIREMENTS FOR SEWER LIFT STATIONS	58
27-1 General Pump Requirements	58
27-2 Sewer Lift Station Site Requirements	59
27-3 Lift Station Wet well Requirements.....	59
27-4 Control Cabinet / Panel Requirements	61

27-5 Control System Operation	62
27-6 Emergency Power Generator	62
27-7 Miscellaneous Lift Station Requirements	63
Part 3- PLATES (DRAWINGS).....	65
Plate 1- Standard Sewer Notes (S-1)	65
Plate 2- Sewer Pipe Bedding and Backfill Details (S-2)	66
Plate 3- Typical Sewer Lateral (S-3).....	67
Plate 4- Lateral Connection to Existing Main (S-4).....	68
Plate 5- Typical House Connection (S-5)	69
Plate 6- Inline Cleanout (S-6)	70
Plate 7- 48" and 60" I.D. Standard Manhole (S-7)	71
Plate 8- Standard Corrosion Resistant Manhole Connection to Existing Outfall Sewer (S-8).....	72
Plate 9- HDPE Outfall Manhole Connection Details (S-9).....	73
Plate 10- Existing HDPE Outfall Sewer and Manhole Connection Detail (S-10) .	74
Plate 11- Manhole Frame and Cover (S-11)	75
Plate 12- Corrosion Resistant Manhole Frame and Cover (S-11A).....	76
Plate 13- Manhole- Drop Inlet (S-12)	77
Plate 14- Steel Casing Conductor Pipe (S-13)	78
Plate 15- Trailer Sewage Disposal Station (S-14).....	79
Plate 16- End of Line Cleanout (S-15)	80
Plate 17- Typical Lift Station Piping Schematic (S-16).....	81
Plate 18- Wet Well Pipe Restraint and Inline Pressure Clean-Out (S-17)	82
Plate 19- Pressure Clean-Out Details (S-18)	83
Plate 20- Grease Interceptor (S-19).....	84
Plate 21- Precast Sampling Structures (S-20)	85
Plate 22- Sand-Oil Interceptor (S-21)	86
Part 4- APPENDICES	87
Appendix A- FORMS	87
Appendix A.1 Sanitary Sewer System Improvements Contract.....	87
Appendix A.2 Grant of Easement.....	93
Appendix A.3 Certificate of Acceptance	94

Appendix A.4 Performance Bond95
Appendix A.5 Payment Bond.....97
Appendix A.6 Contractor’s Certificate Regarding Workers’ Compensation 99
Appendix A.7 Certificate of Insurance for Workers’ Compensation 100
Appendix A.8 Insurance Endorsement for Workers’ Compensation..... 102
Appendix A.9 Certificate of Insurance for Liability Insurance 104
Appendix A.10 Insurance Endorsement for Liability Insurance 108
Appendix B– DISTRICT PROCEDURES CHECKLIST 110
APPENDIX C – GENERAL TESTING REQUIREMENTS 111
APPENDIX D – REPORTING CRITERIA TO COLLECTIONS 112

PART 1- GENERAL PROVISIONS
SECTION 1- GENERAL GUIDELINES

1-1 Definitions

Whenever the following terms or abbreviations occur in these specifications, the meaning shall be interpreted as follows:

BOARD OF DIRECTORS OR BOARD - The Board of Directors of the North of River Sanitary District.

CITY – City of Bakersfield.

CONTRACT - The agreement executed between the Owner and the District covering the sanitary sewer system improvements to be constructed and to become a part of the District's facilities. Said improvements to be described in the Contract.

CONTRACTOR - The person, firm, or corporation constructing the improvements for the Owner. In some instances, the Contractor and Owner may be one and the same.

COUNTY – County of Kern.

DAYS - When used to designate a period of time, shall be in reference to consecutive calendar days.

DISTRICT - North of River Sanitary District, Kern County, California. When the word "District" is used in a sense requiring action, such as, approving, inspection, making a decision, etc., the "District Manager" shall be understood as the person having the authority to take the required action.

DISTRICT MANAGER - The Manager of North of River Sanitary District, his authorized representative, or other such person as may be designated by the Board.

DISTRICT ENGINEER - As appointed by the District from time to time.

FINAL ACCEPTANCE - That formal action by the District accepting the work as fully completed after approval by the District Manager.

INSPECTOR - The Inspector employed by the District to perform inspection during construction of the work undertaken by the Owner.

LABORATORY - A laboratory approved by the District to test materials, and work involved in the contract.

LEGAL ADDRESS OF OWNER - The address given on the Owner's permit is hereby designated as the place which all notices, letters or other communications to the Owner shall be mailed or delivered.

OWNER - The person, firm, or corporation signatory to the Contract constructing the improvements to become a part of the District's facility. In some instances, the Owner and the Contractor may be one and the same.

PERMIT - Authorization by the District in writing allowing the Owner to do, or have done, work within the District on sewer facilities described in the Contract. The Owner shall have the Permit present at the job site and shall present it if demanded by any District representative.

PLANS - The official plans, profiles, typical cross-sections, working drawings, detail drawings and supplemental drawings, or reproductions thereof, approved by the District, which show the locations, character, dimensions and details of the work to be done.

PROJECT OR WORK - The entire public improvement proposed by the Owner to be constructed in whole or in part pursuant to the Contract.

RULES AND REGULATIONS - Rules and Regulations for sewage collection, treatment and Disposal adopted by the District as amended from time to time.

SPECIFICATIONS - The directions, provisions, and requirements approved by the District, pertaining to the method and manner of performing the work shown on the Plans. The Specifications include these Specifications for Sanitary Sewer System Improvements as adopted by the District, and amended from time to time.

STATE SPECIFICATIONS – The Standard Specifications, State of California, Department of Transportation, latest edition.

SURETY - The party or parties who guarantee the fulfillment of the work or a portion of the work, by bonds, and whose signatures are attached to the bond.

1-2 Terms

Whenever in the specification or upon the plans the words directed, required, permitted, ordered, designated, prescribed, or words of similar action are used, it shall be understood that the direction, requirements, permission, order, designation, or prescription of the District Manager is intended and similarly the words approved, acceptable, satisfactory, or words of like import, shall mean approved by, or acceptable to, or satisfactory to the District Manager, unless otherwise expressly stated.

If the Owner and the Contractor are not one and the same, it will be the responsibility of the Owner to see that all provisions of these specifications are met either by the Owner or by their Contractor.

1-3 Abbreviations

Whenever the following abbreviations are used, they shall have the meanings indicated.

ACI	American Concrete Institute
ANSI	American National Standards Institute
ASTM	American Society for Testing and Materials
AWWA	American Water Works Association

1-4 Applicability

In those cases when, in the opinion of the District, circumstances require the design and construction of sewer improvements not adequately covered by these specifications, the District may set different design criteria, require use of other materials, and/or special construction techniques.

1-5 Description of the work

The Owner shall furnish all transportation, materials, equipment, labor and supplies to complete the construction of the sewer system improvements in conformance with the Plans and Specifications.

SECTION 2 – DESIGN CRITERIA PLAN PREPARATION, TESTING, RECORD DRAWINGS AND EASEMENTS

2-1 Preliminary Investigation

The Owner shall meet with the District at the earliest possible date to determine whether or not the property to be developed is within the District boundaries. At this time, the availability of existing sewers may also be reviewed. It shall be the responsibility of the District to determine whether or not the District can serve the proposed development. The Owner shall pay the District for a study and report if deemed necessary by the District.

2-2 Sewer System Design Criteria

The District shall accept flows from the following plumbing fixtures, unless unusual circumstances prevent the District from doing so:

Toilets, urinals, bidets, sinks for domestic faucets, showers, bathtubs, connections for dishwashers, drinking fountains, domestic washing machines and garbage disposals.

Flows which are not acceptable to the District are flows other than sewage, and include, but are not limited to, any and all liquid or processing, commercial, or institutional operations of any kind. Plumbing fixtures or sources hereafter set forth shall not be discharged into the District's sewer system without specific written permission from the District Manager.

All piping from commercial and industrial processing to the sewers.

All floor or stall drains, other than domestic showers.

Swimming pools, ponds, etc., which empty into the sewer system.

Brine from home reiteration water softeners.

Establishments included under the above requirements include, but are not limited to:

Gas stations, car washes, garages, laundromats, etc.

Restaurants, hotels, motels and shopping areas.

The District may require traps, interceptors, pretreatment or other devices on all outlets which may discharge grease, oil, sand or waste material of any kind of a composition or quality deemed harmful by the District.

Pipeline design shall be based on peak flows and on Manning's formula. Use a coefficient of "n" = 0.011 for plastic pipe and "n" = 0.013 for all other pipe. Flows shall be based upon an average of 3.5 persons per single family residential unit at an average disposal rate of 100 gallons per person per day. For commercial land use, flows shall be based upon an average of 3,589 gallons per gross acre per day. For industrial land use, permitting flows shall be based on an average of 4,848 gallons per gross acre per day or as determined by the District.

"Peaking factor" for sewer design shall be not less than 3.0 and shall be approved by the District.

Design peak flows in pipelines 12 inches in diameter and smaller shall be limited to an approximate liquid depth to pipe diameter ratio of 0.50.

Design peak flow in pipelines 15 inches in diameter and larger to be limited to an approximate liquid depth to pipe diameter ratio of 0.75.

Minimum pipeline diameter to be 8 inches.

Minimum pipeline grades:

Pipe Diameter (inch)	Minimum Slope (ft/100 ft)	
	Plastic Pipe (n=0.011)	Other Pipe (n=0.013)
8	0.24	0.35
10	0.18	0.24
12	0.14	0.19
15	0.10	0.14
18	0.08	0.11
21	0.07	0.09
24	0.06	0.08
27	0.05	0.07
30	0.04	0.06
33	0.04	0.05

As a general rule, sewers shall run in a straight line between manholes. All sewer alignments shall be approved by the District.

Minimum depth from finish street grade to top of sewer main pipe shall be six (6) feet. All sanitary sewers and appurtenant structures shall be a minimum of five (5) feet from the roadway center line. In no case shall a sanitary sewer line be located closer than two (2) feet from an existing or proposed gutter lip.

The entire sanitary system shall be located as mentioned above and shall be designed to clear all other existing or proposed utilities by a minimum of twelve (12) inches. Special structures, such as pump stations, pressure lines and sags, etc. shall be subject to the approval of the District Manager.

Sewer manholes are required at:

Changes of direction of sewers.

Changes in slope of sewers.

Junctions of sewers.

Junction of sewer and lateral if lateral is same size as sewer.

Termination of sewer.

Change of pipe size in sewers.

Whenever the vertical distance between the inverts of sewer line connections of a manhole exceeds thirty (30) inches, a standard Drop Manhole shall be constructed.

Other locations specified by the District.

Maximum manhole spacing shall be 400 feet.

Where sewer mains cross development phase lines within a subdivision or across subdivision boundaries, new sewers shall not terminate at the phase line but shall be constructed to the next manhole. No exceptions. Temporary cleanouts installed at the phase line are not allowed. Stubs at manholes shall not exceed 5 feet in length.

Allowable head losses in manholes:

Straight run through manholes based on 0.00 foot loss.

Right angle turn in manholes based on 0.5 velocity head loss, or 0.10 foot, whichever is greater.

No change of flow direction within a manhole shall exceed 90 degrees.

Invert elevation at manholes shall be calculated and shown projected to the centerline of the manhole. Should there be any drop in elevation, the invert elevation "IN" and the direction, N, S, E, or W, and invert elevation "OUT" and the direction shall be shown. Should a pipeline be joining a sewer of larger diameter, the smaller pipe shall have its crown elevation equal to or higher than the crown elevation of the larger sewer.

Separation of water and sewer mains shall be in compliance with the "California Waterworks Standards" discussed in Title 22, Division 4, Chapter 16, Article 4 of the California Code of Regulations and the California Department of Health Services Regulations. Every effort shall be made to adhere to these standards. Any deviation from these standards will require approval of the District Manager.

Gravity Sewer Lines:

Gravity sewer lines shall be laid in separate trenches with a minimum horizontal clear distance of ten (10) feet away from water lines.

Sewer lines shall be laid at a lower elevation than nearby water lines.

When pipelines must cross, the bottom of the water line shall be at least twelve (12) inches above the top of the sewer pipe.

Separation distances specified above shall be measured from the nearest edges of the facilities.

Where steel casings or tunnels are used for the passage of sewer lines under railroad tracks, highways or other structures, the same shall be specially designed to eliminate any hazard of contamination to the water system.

Sewer Force Mains:

Sewer force mains shall be laid in separate trenches with a minimum horizontal clear distance of ten (10) feet away from water lines.

When a sewer force main must cross a water line, the crossing should be as close as practical to the perpendicular. The sewer force main should be at least twelve (12) inches below the water line.

When a new sewer force main crosses under an existing water main, all portions of the sewer force main within ten (10) feet (horizontally) of the water main shall be enclosed in a continuous steel casing.

When a new water main crosses over an existing sewer force main, the water main shall be constructed of pipe materials with a minimum rated working pressure of 200 psi and have no joints within 10 feet of the sewer force main.

2-3 Utility Notification and Potholing

Utility notification for potholing shall be performed by the Contractor prior to commencement of work.

Potholing shall be conducted by the Contractor to verify location of identified utilities and obstructions. Potholing shall be conducted a minimum of 2,500 linear feet ahead of construction. Contractor shall notify the District if there are any discrepancies between the existing utilities and the utilities shown in the plans.

2-4 Testing

Prior to final acceptance, all sanitary sewers shall be tested for leakage and be inspected with video equipment designed for this purpose. The television camera shall have the capability of rotating 360 degrees in order to view and record the top, bottom, and sides of the pipe, as required. The video inspection shall be witnessed by the District's inspector, who will also initial and date the "Chain of

Custody” form. The Owner shall immediately notify the District of any pipe locations revealed to be not in compliance with the specifications. The CCTV inspection video must be recorded and submitted in a digital format as directed by the NORSD Staff. The CCTV inspection video, the completed “Chain of Custody” form and a written log which includes the stationing of all connected laterals of the inspection shall be provided for viewing, and shall be approved by the District prior to acceptance. The stationing on the video and log shall be based on the stationing of the approved plans. After acceptance, the video shall become the property of the District. This inspection, and any re-inspection, shall be at the sole expense of the Owner.

2-5 Plan Preparation

All Plans must be prepared under the direct supervision of a registered civil engineer licensed to practice in the State of California and is independent of the District's engineer. This requirement must be attested to by the Owner's engineer's seal and signature on the Plans. The Plans shall contain the sewer notes per Standard Detail S-1 and note by certificate that the Owner's engineer has prepared the plans to meet or exceed minimum County standards. A note shall be placed on all improvement plans stating that the facilities are to be accepted and maintained by North of River Sanitary District. The Plans will be prepared in ink on mylar or AutoCAD format (24” X 36”).

2-6 Record Drawings

During the construction of the improvements, the Owner shall note deviations from the Plans on a set of the Plans specifically set aside for this purpose. Any such changes shall be made to the originals (reproducible) of the Plans with a suitable note stating that the originals are the “Record Drawing”. The originals accompanied by a 11” X 17” sewer “WYE” map depicting lateral locations shall then be submitted to the District for approval and before issuance of the Notice of Acceptance by the District of the work. No user connections are allowed prior to issuance of the Notice of Acceptance.

2-7 Easements and Permits

In case any easement(s) is required for construction and/or maintenance of sewer facilities, the minimum width shall be 20 feet unless otherwise agreed to in writing by the District. However, there may be instances where easements of a greater width are required as determined by the District. Easements shall be granted and executed prior to approval of the improvement Plans. The form of the grant of easement document shall be approved by the District. Easements shall be shown on the Plans. If a permit is required from another agency, it is the Owner's responsibility to acquire any such permit with the District named as the permittee. If a permit is required, it is to be delivered to the District at the time the proposed final Plans and Specifications are submitted to the District for review.

2-8 Plan Approval

Approval of the Plans by the City or County shall not relieve the Owner of his responsibility to locate all existing utilities and facilities, design the proposed improvements and prepare plans in accordance with these Improvement Standards, and/or detect and correct any and all errors and omissions contained in the Plans.

The City may require additional checking of improvement Plans (with deposit of additional plan check fees) if start of substantial construction of the improvements does not begin within 3 months of original plan approval.

Plans shall be approved in final form prior to execution of the Contract or issuing of the Encroachment Permit.

SECTION 3 – CONSTRUCTION AND INSPECTION

3-1 Governing Specifications

All construction shall be in accordance with these Specifications and Rules and Regulations of the District. The Rules and Regulations, as adopted and/or amended from time to time, are hereby made a part of these Specifications for Sanitary Sewer Systems by reference as though set forth.

3-2 District Permit

In accordance with Kern County Land Division Ordinance Section 18.45.050 Part B, and 18.45.090 Part B, no improvement work shall be done, and no permit shall be issued for the doing of any improvement work, on any land in a subdivision or on any improvement for a subdivision prior to approval and recordation of the final map unless all the conditions of those Sections have been met.

The Owner shall not commence construction until the Permit is issued by the District. The Permit shall not be issued until after approval by the District of the Plans and Specifications, bond and insurance forms, and grant of easement(s), if any, and until after receipt of a check made payable to the District to cover the sewer connection charges, applicable line charges, plan check fees and inspection fees.

3-3 Connection to Existing Facilities

No connection shall be made to existing facilities of the District without prior approval and inspection by representatives of the District.

3-4 Notice

Notice shall be given to the District at least seven (7) working days in advance of commencement of work.

3-5 Other Permits

The Owner shall secure all excavation permits and all licenses, pay all charges and fees, and give all notices as necessary and required for the work by other agencies having jurisdiction. These shall be filed with the District at least two (2) weeks prior to commencement of work.

3-6 Construction Water

Water used for construction, testing and dust control shall be arranged for and furnished by the Owner at his expense.

3-7 Inspection

All work shall be subject to inspection by the District and shall be left open and uncovered until the work is approved by the District.

The District shall at all times have access to the work during construction and shall be furnished with every reasonable facility for ascertaining full knowledge respecting the progress, workmanship and character of materials used and employed in the work.

No pipe, fittings or other materials shall be installed until inspected and approved by the District. Installations which are to be backfilled shall be inspected and approved by the District prior to backfilling, and the Owner shall give due notice in advance of backfilling to the District so that proper inspection may be provided. If the installations are backfilled prior to inspection, the District may require the installation to be exposed for inspection or have a video inspection be performed at the Owner's expense.

Inspection of the work by the District shall not relieve the Owner of his obligation to complete the work as prescribed by the Plans and Specifications approved by the District. Defective work shall be made good, and unsuitable materials may be rejected notwithstanding the fact that such defective work and unsuitable materials have been previously overlooked by the District and accepted. The installation and inspection of unsuitable materials shall not be construed as acceptance and modification to these specifications shall only be made by the District in writing.

The District shall have the authority to suspend the work wholly or in part for such time as it may deem necessary due to the failure on the part of the Owner to carry out an order given or to perform any provisions of the District approved Plans and Specifications. The Owner shall immediately comply with the order of the District to suspend the work wholly or in part. The work shall be resumed when methods or defective work are corrected as ordered by the District. Failure to comply with requests of the District may prevent the Notice of Acceptance of the Project which may prevent occupancy of the development.

All construction shall be done in compliance with the standards as established by the Occupational Safety and Health Act (OSHA/Cal-OSHA) and appropriate State of California regulations.

SECTION 4 – CONTROL OF MATERIAL

4-1 Quality of Materials

All equipment, material and supplies to be incorporated in the work shall be new unless otherwise specified and shall conform to the requirements stated in the Plans and Specifications approved by the District.

4-2 Defective Materials

All materials not conforming to the requirements of the approved Plans and Specifications shall be considered as defective and all such materials, whether in place or not, shall be rejected and shall be removed immediately from the site of the work unless otherwise permitted by the District. No rejected material, the defects of which have been subsequently corrected, shall be used until approved in writing by the District. Upon failure on the part of the Owner to comply with any order of the District made under the provisions of this article, the District shall have authority to remove and replace defective material at the expense of the Owner.

4-3 Storage of Materials

All materials for use in the work shall be stored in such a manner as to prevent damage from exposure to the elements, admixture of foreign materials or from any other cause. The Owner shall be fully responsible for any damage incurred to the materials for the work while being stored, including damage resulting from storing of material in public right-of-way and District acquired easements. The Owner shall also be fully responsible for the preservation of public and private property while storing materials for the work.

SECTION 5 – USE OF COMPLETED PORTIONS

When the work or any portion of it is sufficiently complete to be utilized or placed into service, the District shall have the right upon written notification to the Owner to utilize such portions of the work and to place the operable portions into service and to operate same.

Upon said notice of commencement of utilization or operation by the District, the Owner shall be relieved of the duty of maintaining the portions so utilized or placed into operations; provided, however, that nothing in this article shall be construed as relieving the Owner of the full responsibility for completing the work in its entirety, for making good defective work and materials, for protecting the work from damage, and for being responsible for damage and such action shall not relieve the Owner, his Surety, or insurers of the provisions of the section on INSURANCE REQUIREMENTS.

SECTION 6 – LEGAL RELATIONS AND RESPONSIBILITIES

6-1 Observing Laws and Ordinances

The Owner shall at all times observe and comply with and shall cause his Contractor, if different from the Owner, agents, employees, subcontractors and suppliers to observe and comply with all such existing and future laws, ordinances, regulations, orders and decrees and shall hold harmless, indemnify and defend the District, the District's Engineer and each of their directors, officers, employees and agents against any claim or liability arising from or based on the violation of any such law, ordinance, regulation, order or decree by the Contractor, his employees, agents, subcontractors or suppliers.

6-2 Permits and Licenses

The Owner shall procure all permits and licenses, pay all charges and fees, and give all notices necessary and incidental to the due and lawful prosecution of the work.

6-3 Inventions, Patents and Copyrights

The Owner shall pay all royalties and assume all costs arising from the use of any invention, design, process, materials, equipment, product or device which is the subject of patent rights or copyrights.

The Owner shall hold harmless, indemnify and defend the District, the District's Engineer, and their consultants, all other District consultants, and each of foregoing's directors, officers, employees and agents from and against all claims, damages, losses, expenses and other costs, including costs of defense and attorney's fees, arising out of any infringement of patent rights or copyrights incident to the use in the performance of the work or resulting from the incorporation in the work of any invention, design, process, material, equipment, product or device and shall defend all such claims in connection with any alleged infringement of such rights.

6-4 Public Convenience and Safety

The Owner shall so conduct his operations as to offer the least possible obstruction and inconvenience to the public, and he shall have under construction no greater length or amount of work than he can prosecute properly with due regard to the rights of the public.

Convenient access to driveways, houses and buildings along the line of work shall be maintained and temporary crossings shall be provided and maintained in good condition. Not more than one crossing or intersecting street or road shall be closed at any one time.

The Owner shall provide and maintain such fences, barriers, directional signs, lights and flagmen as are necessary to give adequate warning to the public at all times of any dangerous conditions to be encountered as a result of the construction work and to give directions to the public.

6-5 Responsibility for Loss, Damage or Injuries

The Owner shall be responsible for all claims, demands or liability from any cause arising out of or resulting from or in connection with the performance of the work, excepting only those as may be caused solely and exclusively by the fault or negligence of the District's Engineer, or their consultants, all other District consultants, or their directors, officers, employees and agents. Such responsibility shall extend to claims, demands, or liability for loss, damage or injuries occurring after completion of the work as well as during the progress.

6-6 Owner's Responsibility for the Work

Until the final acceptance of the work, the Owner shall have the responsible charge and care of the work and of the materials to be used therein (including materials which have been furnished by the District) and shall bear the risk of injury, loss or damage to any part thereof by the action of the elements or from any other cause, whether arising from the execution or from the nonexecution of the work.

The Owner shall rebuild, repair, restore and make good all injuries, losses or damages to any portion of the work or the materials occasioned by any cause before its completion and acceptance and shall bear the expense thereof. Where necessary to protect the work or materials from damage, the Owner shall at his expense provide suitable drainage and erect such temporary structures as are necessary to protect the work or materials from damage. The suspension of the work or the granting of an extension of time from any cause whatever shall not relieve the Owner of his responsibility for the work and materials as herein specified.

In an emergency affecting the safety of life or property, including adjoining property, the Owner, without special instructions or authorizations, is authorized to act at his discretion to prevent such threatened loss or injury.

6-7 Preservation of Property

The Owner shall exercise due care to avoid injury to existing improvements or facilities, utility facilities, adjacent property, and trees and shrubbery that are not to be removed.

All trees, shrubbery and landscaping that are not to be removed, and pole lines, fences, signs, survey markers and monuments, buildings and structures, conduits, pipelines under or above ground, sewer and waterlines, all highways or street facilities, and any other improvements or facilities within or adjacent to the work shall be protected from injury or damage, and the Owner shall provide and install suitable safeguards to protect such objects from injury or damage. If such objects are injured or damaged by reason of the Owner's operation, they shall be replaced or restored at the Owner's expense to a condition as good as when the Owner entered upon the work or as good as required by the Plans and Specifications if any such objects are a part of the work being performed.

The fact that any such pipe or other underground facility is not shown on the Plans shall not relieve the Owner of his responsibility under this article.

In addition to any requirements imposed by law, the Owner shall shore up, brace, underpin and protect as may be necessary, all foundations and other parts of all existing structures adjacent and adjoining the site of the work which are in any way affected by the excavations of other operations connected with the performance of the work. Whenever any notice is required to be given by the Owner to any adjacent or

adjoining landowner or other party before commencement of any work, such notice shall be given by the Owner.

6-8 Safety

The Owner shall be solely and completely responsible for conditions of the job site, including safety of all person and property during performance of the work, and the Owner shall fully comply with all state, federal and other laws, rules, regulations and orders relating to safety of the public and workers.

The right of the District to conduct construction review or observation of the work will not include review or observation or the adequacy of the Owner's safety measures in, on or near the construction site.

6-9 Personal Liability

Neither the Board of Directors, the District Manager, the District's Engineer and their consultants, all other District consultants, nor any other officers or agents of the District shall be personally responsible for any liability arising under or by virtue of the Contract.

6-10 Indemnity

To the fullest extent permitted by law, the Owner shall indemnify and hold harmless the District, District's Engineer, District consultants, and each of their consultants, all other District consultants, and each of their directors, officers, agents and employees from and against all claims, damages, losses, expenses and other costs, including costs of defense and attorney's fees, arising out of or resulting from or in connection with the performance of the work, both on and off the job site, provided that any of the foregoing (1) is attributable to personal injury, bodily injury, sickness, disease or death, or to injury to or destruction of tangible property (other than the work itself), including the loss of use resulting therefrom and (2) is caused in whole or in part by any act or omission of the Owner, the Contractor, if different from the Owner, any subcontractor, any supplier, anyone directly or indirectly employed by any of them or anyone for whose acts or omissions any of them may be liable, regardless of whether or not it is caused in part by any act or omission (active, passive or comparative negligence included), of a party indemnified hereunder.

In any and all claims against the indemnified parties by any employee of the Owner, the Contractor, if different from the Owner, any subcontractor, any supplier, anyone directly or indirectly employed by any of them or anyone for whose acts any of them may be liable, the indemnification obligation under the first and fourth paragraphs in this article on INDEMNITY shall not be limited in any way by any limitation on the amount or type of damages, compensation or benefits payable by or for the Owner, the Contractor, if different from the Owner, or any subcontractor, or any supplier or other person under workers' compensation acts, disability benefit acts or other employee acts.

The obligations of the Owner under the first and fourth paragraphs in this article on INDEMNITY shall not extend to the liability of the District's Engineer and their consultants, all other District consultants, each of their directors, officers, employees, and agents, arising out of or resulting from or in connection with the preparation or approval of maps, drawing, opinions, reports, surveys, designs or specifications, providing that the foregoing was the sole and exclusive cause of the loss, damage or injury.

The Owner shall also indemnify and hold harmless the District, the District's Engineer and their consultants, all other District consultants, and each of foregoing's directors, officers, employees and

agents from and against all losses, expenses, damages (including damages to work itself), attorney's fees and other costs, including all costs of defense, which any of them may incur with respect to the failure, neglect, or refusal of Owner to faithfully perform the work and all of the Owner's obligations under the Contract. Such costs, expenses and damages shall include any cost, including attorney's fees, incurred by the indemnified parties in any lawsuit to which they are a party.

6-11 Warranty of Title

No materials, supplies or equipment for the work under this contract shall be purchased subject to any chattel mortgage or under a conditional sales contract or other agreement by which an interest therein or any part thereof is retained by the seller or supplier. The Owner warrants clear and good title to all material, supplies and equipment installed and incorporated in the work and agrees upon completion of all work to deliver the premises together with all improvements and appurtenances constructed or placed thereon by him to the District free from any claims, liens, encumbrances or charges and further agrees that neither he nor any person, firm or corporation furnishing any materials or labor for any work covered by the Contract shall have any right to a lien upon the premises or any improvements or appurtenances thereon, provided that this shall not preclude the Owner from installing metering devices of other equipment of utility companies or of municipalities, the title of which is commonly retained by the utility company or the municipality. Nothing contained in this article, however, shall defeat or impair the right of such persons furnishing materials or labor under any bond given by the Owner for their protection, or any right under any law permitting such persons to provisions of this article shall be inserted in all subcontracts and material contracts, and notices of its provision shall be given to all persons furnishing materials for the work when no formal contract is entered into for such materials.

6-12 Termination for Breach

If the Owner refuses or fails to prosecute the work or any separable part thereof with such diligence as will insure its completion within the time specified in the permit, or any extension thereof, or fails to complete such work within such time, or if the Owner should be adjudged a bankrupt, or if he should make a general assignment for the benefit of his creditors, or if a receiver should be appointed on account of his insolvency, or if he, his Contractor, if different from the Owner, or any of his subcontractors should violate any of the provisions of the Permit, the District may serve written notice upon the Owner and his Surety of its intention to terminate the Permit, said notice to contain the reasons for such intention to terminate the Contract, and unless within ten (10) days after the service of such notice such violations shall cease and satisfactory arrangements for the corrections thereof be made, the Permit shall, upon the expiration of said ten (10) days, cease and terminate.

In the event of any such termination, the District shall immediately serve written notice thereof upon the Surety, the Owner, and the Surety shall have the right to take over and perform the Contract, providing, however, that if the Surety within fifteen (15) days after the serving upon it of a notice of termination does not give the District written notice of its intention to take over and perform the Contract, or does not commence performance thereof within thirty (30) days from the date of serving said notice, the District may take over the work and prosecute the same to completion by Contract or by any other method it may deem advisable for the account and at the expense of the Owner, and his Surety shall be liable to the District may take over the work and prosecute the same to completion by Contract or by any other method it may deem advisable for the account and at the expense of the Owner, and his Surety shall be liable to the District for any excess cost or other damage occasioned the District hereby, and in such event the District may, without liability for so doing, take possession of and utilize in completing the work such

materials, appliances, plants and other property belonging to the Owner that may be on the site of the work and be necessary therefor.

The foregoing provisions are in addition to any in limitation of any other right or remedies available to the District.

6-13 Notice and Service Thereof

Any notice required or given under the Contract shall be in writing, be dated and signed by the party giving such notice or his duly authorized representative, and be served as follows:

If to the District, by personal delivery or by deposit in the United States mail.

If to the Owner, by personal delivery to the Owner or to his authorized representative or by deposit in the United States mail.

If to the Surety or any other person, by personal delivery to said Surety or other person or by deposit in the United States mail.

All mailed notices shall be in sealed envelopes, shall be sent by certified mail with postage prepaid and shall be addressed to the addresses in the Contract documents or such substitute addresses which a party designates in writing.

SECTION 7 – INSURANCE REQUIREMENTS

7-1 General

Construction shall not commence, or continue, until or unless there is in full force and effect all required insurance. The Owner shall not permit any work to be done unless and until the Workers' Compensation Insurance and Liability Insurance requirements have been complied with.

The types of insurance the Owner's Contractor shall obtain and maintain are Workers' Compensation Insurance and Liability Insurance, all as set forth herein.

Workers' Compensation Insurance and Liability Insurance shall be maintained in full force and effect for the full warranty period of one year from the date of Notice of Acceptance.

Insurers must be authorized to do business and have an agent for service of process in California and have an "A" policyholder's rating and a financial rating of at least Class XI in accordance with the most current Best's Rating.

As evidence of specified insurance coverage, the Owner shall provide certificates of insurance and endorsements on the forms provided as a part of these Specifications. No alteration or substitution of said forms will be allowed.

7-2 Workers' Compensation Insurance

The Owner shall provide a certificate(s) of insurance certifying that his Contractor has obtained for the period of the Contract full Workers' Compensation Insurance coverage for all persons whom he employs or may employ in carrying out the work under the Contract. This insurance shall be in strict accordance with the requirements of the most current and applicable state Workers' Compensation Insurance laws.

7-3 Liability Insurance

The Owner shall provide a certificate(s) of insurance showing his Contractor has the Liability Insurance coverage stated in the Contract.

Included in such insurance shall be contractual coverage sufficiently broad to insure the matters set forth in the article entitled "INDEMNITY" in the General Provisions except those matters set forth in the fourth paragraph thereof.

The Liability Insurance coverage shall include each of the following types of insurance:

- A. General Liability
 - (1) Comprehensive Form
 - (2) Premises-Operations
 - (3) Explosion and Collapse Hazard
 - (4) Underground Hazard
 - (5) Products/Completed Operations Hazard
 - (6) Contractual Insurance
 - (7) Broad Form Property Damage Including Completed Operations
 - (8) Independent Contractors
 - (9) Personal Injury

- B. Automobile Liability
 - (1) Comprehensive Form Including Loading and Unloading
 - (2) Owned
 - (3) Hired
 - (4) Non-Owned

The Liability Insurance shall include as additional insureds: the District, the District's Engineer and their consultants, all other District consultants, and each of their directors, officers, agents and employees. The insurance afforded to these additional insureds shall be primary insurance. If the additional insureds have other insurance which might be applicable to any loss, the amount of the insurance provided under this article on LIABILITY INSURANCE shall not be reduced or prorated by the existence of such other insurance.

SECTION 8 – CONSTRUCTION SECURITY

8-1 General

Performance and Payment Bond, or a Guarantee Bond shall be secured from a surety company, or companies, satisfactory to the District and whose name is on file with the County Clerk of Kern County as an approved and financially sound surety company, authorized to transact business in this state. The District shall provide the bond forms to be used. No alteration or substitution of said forms shall be allowed.

The bonds shall meet all of the requirements and contain all of the conditions required by State of California law.

The bonds shall also warrant all work performed under the Contract to be free from defects in material and/or workmanship for a period of one year from the date of Notice of Acceptance by the District.

The bonds shall be delivered to the District prior to issuance of the Permit.

The Owner shall submit copies of proposals received from Contractors bidding on constructing the improvements or other evidence satisfactory to the District to establish the project construction costs for purposes of bonding. If bonding is required by the County of Kern, the District shall waive this requirement.

8-2 Performance Bond

The Owner may furnish a surety bond in the amount of one hundred percent (100%) of the Project construction cost to the benefit of the District, as security for the faithful performance of the Work or Contract in compliance with the District Ordinances, Rules and Regulations, and the Plans and Specifications.

8-3 Payment Bond

The Owner may furnish a separate bond in an amount of one hundred percent (100%) of the Project construction cost to the benefit of the District, as security for the payment of all persons performing labor and furnishing materials in connection with the Contract.

8-4 Guarantee Bond

The District may at its sole discretion waive the requirements for Performance and Payment Bonds and require instead a Guarantee Bond guaranteeing the Work will be free from defects as a result of faulty workmanship and materials for a period of one year from the date of Notice of Acceptance by the District of the Work. The amount of any such Guarantee Bond will be determined by the District.

SECTION 9 – FINAL ACCEPTANCE OF THE WORK BY THE DISTRICT

Following final testing and inspection of the facilities constructed under the Contract, the District will accept, in writing, from the Owner the completed facilities as described in the Contract.

Part 2- TECHNICAL SPECIFICATIONS

SECTION 10- EARTHWORK

10-1 General

Earthwork shall consist of performing operations necessary to complete all excavation, preparation of subgrade, ditching, structural excavation, trenching, backfill compacting, sloping, trimming the subgrade, and finish grading. These specifications designate the requirements for earthwork in connection with construction of pipelines, manholes, valves, and all other appurtenances required and approved by the District.

Earthwork shall also include all clearing and grubbing, removal and disposal of paving, removal of water, excavation of all classes of earth and rock regardless of character and subsurface conditions and disposal of all excess excavation.

10-2 Earthwork in State, County, and City Rights-Of-Way

Earthwork within the rights-of-way of the State of California, County of Kern and City of Bakersfield shall be done in accordance with requirements and provisions of the permits issued by those agencies for the construction within their respective rights-of-way. Such requirements and provisions, where applicable, shall take precedence and supersede the provisions of the specifications contained herein if more restrictive.

10-3 Safety Precautions

All excavations shall be performed, protected and supported as required for safety and in the manner set forth in the operation rules, orders and regulations prescribed by the Division of Occupational Safety and Health of the State of California (Cal/OSHA). Barriers shall be placed at each end of all excavations and at such places as may be necessary along excavations to warn all pedestrian and vehicular traffic of such excavations.

10-4 Bracing Excavations

All excavations shall be properly supported in the manner prescribed by the rules, orders and regulations of Cal/OSHA. Excavations shall be so braced, sheeted and supported that they will be safe and the ground alongside the excavation will not slide or settle, and all existing improvements of any kind, either on public or private property, will be fully protected from damage. If any damage does result to such improvements, the Owner, at his own expense, shall make the necessary repairs or reconstruction required as directed by the District.

Excavations shall be so braced or sheeted so as to provide conditions under which workmen may work safely and efficiently at all time. The sheeting, shoring and bracing shall be so arranged as not to place any stress on portions of the completed work until the general construction thereof has proceeded enough to

provide ample strength. Any damage to structures occurring through settlements, water or earth pressures, slides, cave-ins or other causes shall be repaired before acceptance by the District.

Where timber sheeting extends below the invert of the pipe, it shall be cut off at the top of the pipe and the upper portion removed without harming the support conditions. This requirement will not be necessary where steel sheeting is used for shoring below the invert of the pipe.

Care shall be exercised in the drawing or removing of sheeting, shoring, bracing and timbering to prevent the caving or collapsing of the excavation faces which are being supported.

10-5 Open Excavations and Stockpiling

Open excavations and stockpiles shall be controlled in a manner to prevent water running into excavations. Obstruction of surface drainage shall be avoided and means shall be provided whereby storm and wastewater can flow uninterrupted in existing or established flowage courses, other surface drains, or temporary drains. Material for backfill or for protection of excavation in public roads from surface drainage shall be neatly placed and kept shaped so as to cause the least possible interference with public travel. Free access must be provided to all fire hydrants, water valves, meters, private drives, roads or existing access routes.

10-6 Selected Material for Pipe Bedding and Pipe Zone

Selected material for pipe bedding shall be selected native material free from clods, stick, vegetation, chunks of asphalt paving, or other deleterious materials and shall be free of rocks or stones which are larger than 3/4-inch in greatest dimension.

10-7 Sand

If sand is to be used for pipe bedding or pipe zone, it shall be free from foreign materials such as rocks, sticks, vegetation, etc., and shall meet the following gradation:

Sieve Size	Percentage Passing (By Weight)
3/8-inch	100
No. 4	75 - 100
No. 30	12 - 50
No. 100	5 - 20
No. 200	0 - 10

10-8 Aggregate for Pipe Bedding Foundation and Pipe Zone

If aggregate is used for pipe bedding foundation shall conform to the sieve sizes below and shall be free from foreign and organic matter.

Sieve Size	Percentage Passing (By Weight)
------------	-----------------------------------

1/2-inch	100
3/8-inch	90 - 100
No. 4	30 - 60
No. 8	0 - 10

10-9 Obstructions

All underground improvements shall be preserved and protected. Where it is necessary to remove and replace or to relocate such improvements in order to prosecute the work, they shall be removed, maintained in operation, and permanently replaced as directed by the Owner of the discovered obstruction or as directed by the District.

10-10 Compaction Tests

Backfill of excavations within the rights-of-way of City or County streets and State highways shall be done in accordance with the requirements and to the satisfaction of the respective agencies.

Compaction in areas not in State, City or County rights-of-way shall be tested at locations selected by the District and in accordance with the methods specified by ASTM D1557.

The Owner shall test for compaction as follows:

Determine the density of the soil in place by the sand cone method, ASTM D 1556 or by nuclear methods, ASTM D6938.

Determine laboratory moisture-density relations of soils by ASTM D1557.

Determine the relative density of cohesionless soils by ASTM D4253 and D4254.

Sample backfill materials by ASTM D75.

“Relative compaction” is the ratio, expressed as a percentage, of the in place dry density to laboratory maximum dry density.

Where compaction tests indicate a failure to meet the specified compaction, the Owner will take additional test every 25 feet in each direction until the extent of the failing area is identified. Rework the entire failed area until the specified compaction has been achieved.

The Owner shall pay all costs for testing and retesting of work not conforming to the Specifications.

All testing results shall be submitted to the District for approval.

10-11 Correction of Faulty Grades

Where excavation is inadvertently carried below subgrade and/or foundation elevations, suitable provision shall be made for adjustment of the subgrade. The subgrade or foundation shall be restored to a condition similar to the condition existing prior to the over-excavation and by means acceptable to the District.

10-12 Clearing and Grubbing

All trees, brush, roots and other perishable and objectionable material shall be removed from the project.

The ground surface of all areas where material is to be excavated or where embankments, stockpiles, fills or structures are to be placed, shall be cleared of all vegetation and rubbish, and all brush, roots and tree roots shall be grubbed and removed from such areas. All cleared and grubbed areas shall be maintained free from vegetal growth.

Organic material from clearing and grubbing operations will not be incorporated in pipe backfill.

10-13 Blasting and Explosives

Written permission of the District shall be obtained prior to any blasting or use of explosives. Explosives, if used, shall be of such quantity and power and shall be used in such locations so as to minimize opening of seams and disturbing of the material outside the prescribed limits of excavation. As excavation approaches its final limits, the depths of holes for blasting and the quantity of explosives used for each hole shall be reduced so that the underlying or adjacent material will be disturbed or shattered as little as possible.

Extreme care shall be exercised when blasting in the vicinity of existing structures, utilities or construction facilities of other.

All blasting shall be done in conformance with the provisions of the Construction Safety Orders of the California Department of Industrial Relations, California Administrative Code, Title 8, Article 5.

10-14 Dewatering

There shall be provided and maintained at all times during construction ample means and devices with which to promptly remove and properly dispose of all water from any source entering the excavations or other parts of the work. Dewatering shall be accomplished by methods which ensure a dry excavation and preservation of the final lines and grades of the bottom of excavations. Said methods may include well points, sump pumps, suitable rock or gravel placed below the required bedding for drainage and pumping purposes, temporary pipelines and other means, all subject to the approval of the District.

Dewatering for structures and pipelines shall commence when groundwater is first encountered and shall be continuous until such times as water can be allowed to rise in accordance with the provisions of this section. No concrete footing or floors shall be laid in water nor shall water be allowed to rise over them until the concrete or mortar has set at least eight hours. Water shall not be allowed to rise unequally against walls for a period of 28 days.

Water from the work shall be disposed of in a suitable manner without damage to adjacent property. No water shall be drained into work built or under construction without prior consent of the District. Water shall be disposed of in such a manner as not to be a menace to the public health.

Section 11- PIPELINE AND TRENCH EARTHWORK

11-1 General

Work in connection with pipeline and trench earthwork shall include but not be limited to any or all of the following described operations: clearing; excavation of all classes and of whatever substance encountered; backfilling; fine grading; preparation of right-of-way; subgrade for pipe and structures; and paving and performing any other similar, incidental, or appurtenant earthwork operation which may be necessary to properly complete the work indicated. Trenching and backfilling requirements are shown in the Standard Detail S-2.

11-2 Excavation For Pipe Trenches

Trenches for pipelines shall be excavated to the lines and grades required and as approved by the District.

11-3 Trench Width

The overall trench width shall not be more than 16 inches or less than 12 inches wider than the largest outside diameter of the pipe to be laid therein, measured at a point 12 inches above the top of the pipe. Excavating and trenching shall be true to line so that a clear space of not more than 8 inches or less than 6 inches in width is provided on each side of the largest outside diameter of the pipe in places. For the purposes of this article, the largest outside diameter shall be the outside diameter of the bell, on bell and spigot pipe, and outside diameter of coupling for sleeve coupling pipe.

Where the trench width, measured at a point 6 inches above the top of the bell or sleeve of the pipe is wider than the maximum set forth above, the trench area around the pipe shall be reworked to restore a trench condition acceptable to the District. The reworking may result in one or more of the following operations, subject to the approval of the District: (1) Shaping the bottom of the trench to fit the pipe; (2) Placing sand around the pipe and to a point 6 inches above the top of the pipe; (3) Lowering the grade of the pipe until the trench condition can be met; (4) Installing a concrete cradle for the pipe; and (5) Providing concrete encasement for the pipe to a point 3 inches above the top of the pipe.

11-4 Limit Of Excavation

Except by special permission of the District, the maximum length of open trench shall not exceed 600 feet in the aggregate at any one location including excavation, construction, pipe laying and backfilling. In addition, at locations where access may be somewhat limited, requiring rerouting of traffic unnecessarily, the District may reduce the maximum length of open trench permitted.

11-5 Trench Bottom For Pipe

The trench shall be excavated to the established grade line of the outside bottom of the pipe. The bottom of the trench shall be scarified to a minimum depth of 3 inches below the bottom of the pipe and uniformly graded to produce a firm but yielding subgrade which will provide uniform support of the pipe along the full length of each section. The bedding materials so prepared throughout a minimum depth of 3 inches shall meet the requirements of these specifications.

If it becomes necessary to excavate below the established grade line in order to remove boulders or other interfering objects, the voids shall be filled with material densified in the manner specified for bedding materials.

Where excavation is in rock, hardpan, shale, or other similar hard and unyielding materials, the trench shall be excavated to a depth at least 6 inches below the established grade line of the outside bottom of the pipe and filled with material as specified in these specifications to grade line. The subgrade shall then be completed as previously stated. The material so placed shall be compacted to 95% relative compaction.

When excavation is in soft, unstable or excessively wet material which is unsuitable as a foundation for the pipe, such material shall be removed as directed by the District and replaced with imported sand or aggregate to a depth approximately 6 inches below the grade line. The subgrade shall then be completed to the underside of the pipe using imported sand or aggregate.

At each joint in the pipe, the bottom of the trench shall be recessed in such a manner as to relieve the bell of the pipe or the pipe coupling of all load and to ensure continuous bearing along the pipe barrel upon the bedding material.

11-6 Trench Backfill

All trenches shall be backfilled after pipe, fittings and appurtenances have been installed. Whenever a relative compaction requirement value is specified herein, it shall be a percentage of the maximum density as determined hereafter. Optimum moisture content and maximum density shall be determined in accordance with ASTM D 1557 and density of soil in place shall be determined using methods approved by the District.

All wood and waste material shall be removed from excavation preparatory to backfilling. Backfilling material shall be approved in all cases by the District and shall be free of trash, wood, large rock, or other objectionable debris. Backfilling shall include the refilling and compaction of the fill in trenches of excavations up to the subgrade of the street or to the existing ground surface.

11-7 Pipe Bedding

The pipe shall be carefully bedded during initial pipe zone backfill operations by hand placing, slicing with a shovel and tamping or “walking in” the material under the lower sector of the pipe to produce firm support for the full length of the barrel with full bearing on said bottom segment of the pipe equal to a minimum of five-tenths of the outside diameter of the barrel.

11-8 Procedure At Pipe Zone

Subsequent backfill in the pipe zone shall consist of placing material as specified in these Specifications simultaneously on each side of the pipe for the full width of the trench and compacting said material to a relative compaction of 95% within the limits of the pipe zone. The pipe zone shall be considered to extend 12 inches above the top of the outside diameter of the pipe.

The pipe shall be carefully bedded by hand placing and compacting selected clean imported sand or aggregate as provided herein from the pipe foundation and/or subgrade to the spring line for the pipe prior

to backfilling above the pipe within the “pipe zone”. Clean imported sand or aggregate shall be used for the pipe bedding when excavated materials are not suitable for pipe bedding or required for the plans.

The pipe bedding, using either selected material, clean imported sand, or aggregate shall be compacted by approved methods to a relative compaction of 95%. The pipe bedding backfill shall be brought to optimum moisture content and shall be placed in layers not exceeding 6 inches in thickness and each layer shall be solidly tamped with the proper tools so as not to injure, damage or disturb the pipe to assure proper protection of the pipe. Water settling for compaction may be approved by the District in the event the foundation and bedding materials are sufficiently granular and sandy in nature that the required compaction will be obtained.

Where the pipe zone extends into the street zone the portion of the pipe zone within the street zone shall be compacted as set forth in these specifications.

11-9 Procedure Above Pipe Zone

The remaining portion of the trench to within 2-1/2 feet of the finished roadway surface or ground surface, as the case may be, shall be backfilled, compacted and/or consolidated to obtain a relative density of 90%. Backfilling may be done with native trench side material except that no oil cake, bituminous pavement, concrete, rock or other lumpy material shall be used in the backfill, unless these materials are scattered and do not exceed 3 inches in any dimension. Material or perishable, spongy, or otherwise improper nature shall not be used in backfilling and no material greater than 3 inches in any dimension shall be placed within 1 foot of any pipe, manhole or structure.

11-10 Compaction In Open Fields

In open fields, where paving or structures will not be above the excavated area, backfill and compaction shall extend to the top of the trench, leaving the top slightly mounded.

11-11 Procedure At Street Zone

The top 2-1/2 feet of the trench within roadbed area shall be compacted in horizontal layers not exceeding 8 inches in thickness, using approved hand, pneumatic or mechanical type tampers to obtain a relative density of 95% with a moisture content within 2% of optimum. If trench is outside roadbed, area shall be compacted to 90% relative compaction with a moisture content within 2% of optimum. Flooding and jetting will not be permitted within roadbed areas. Compaction requirements in the street zone may be modified by the backfill requirements of other government agencies in areas where these agencies have jurisdiction.

The roadbed area is used herein shall be considered as extending two feet beyond the curbs, gutters and paved shoulders.

From existing street grade to 2-1/2 feet below street grade, the material for backfill may contain stones ranging in size up to 2 inches in diameter in quantity, but not exceeding 20% of the volume where said coarse materials are well distributed throughout the finer material and the specified compaction can be obtained.

11-12 Excess Excavated Material

All surplus material not required for backfill shall be disposed of by Owner outside the limits of the public right-of-way and/or easements.

No excavated material shall be deposited on private property, unless written permission is secured by the Owner. Before the District will accept the work as being completed, the Owner shall file a written, notarized release signed by all property owners with whom he has entered into agreements for disposal of excess excavated material, absolving the District from any liability connected therewith.

11-13 Imported Pipe Backfill Material

Whenever the excavated material is not suitable for backfill, in the opinion of the District, suitable imported material shall be used for pipe backfill.

Section 12– STRUCTURES EARTHWORK

12-1 General

Structure excavation shall include the removal of all material of whatever nature necessary for the construction of structures and foundations required and so approved by the District.

The sides of excavation for structures where all vertical surfaces are formed shall be sufficient to leave at least 2 feet in the clear as measured from the extreme outside of formwork or the structure, as the case may be. Where excavation is inadvertently carried below designated elevations, suitable provision shall be made for adjustments of construction, as directed by the District, to meet requirements incurred by the deeper excavation beneath structures, and over depth excavation in such locations shall be rectified by backfilling with sand, graded gravel, or concrete as directed by the District. All over depth excavation for footings shall be backfilled with Class C concrete as defined in the Technical Specification for Concrete Construction.

12-2 Subbase for Structures

Where required and as approved by the District, a crushed rock subbase shall extend from firm ground undisturbed by construction operations to the structure base slab for all concrete structures. Any remaining disturbed or loose material shall be removed before the crushed rock subbase is placed. The subbase shall be compacted to the specified relative compaction, 95% minimum or as approved by the District, by means of a vibratory compactor.

12-3 Subbase Materials

Mineral aggregate shall conform with the following gradation requirements:

Sieve Size	Percent Passing Sieves
3/4-inch	90 - 100
No. 4	40 - 60
No. 30	13 - 23
No. 200	0 - 2

12-4 Backfilling

After completion of foundation footings and walls of the structure and of other construction below the elevation of the final grade and prior to backfilling, all forms shall be removed, and the excavation shall be cleared of debris. Backfilling shall not be commenced until the structure and excavation involved have been inspected and approved by the District. Material for backfilling shall consist of selected excavation material, imported sand, gravel or other material approved by the District and shall be free of trash, lumber or other debris. No material of a perishable or spongy nature and no stone or piece of rock greater than 4-inches in the greatest dimension shall be used in backfilling.

Compaction shall be obtained by means of mechanical tamping. Backfill of excavated material shall be placed in horizontal layers not exceeding 8-inches in thickness and shall have a moisture content such that the required degree of compaction may be obtained. Each layer shall be compacted by hand or machine tampers or by other suitable equipment or means to the specified relative compaction, 95% minimum or as indicated in the plans or as approved by the District.

Where backfill or fill is against only one side of a concrete structure, no fill shall be placed until the concrete in place has obtained an acceptable seven-day strength based upon a concrete cylinder test, unless otherwise directed by the District.

Particular care shall be exercised when backfilling at the various structures to obtain adequate compaction beneath pipes connected thereto and to avoid injury or displacement of such pipes or projections of the structure.

Section 13- VITRIFIED CLAY SEWER PIPE AND FITTINGS

13-1 General

These specifications designate the requirements for furnishing, installation and testing of vitrified clay pipe (VCP), fittings and appurtenances to be used for gravity flow sewer systems. Pipe shall not be stored on the roadways or parkways of residential streets for more than ten days or upon business streets for more than three days.

Excavation and backfill, including the pipe bedding, shall conform to provisions of the Technical Specifications for Earthwork.

13-2 Materials

All VCP and fittings shall be of one class designated extra strength; of the best quality; vitrified; homogeneous in structure; thoroughly burned throughout their entire thickness; impervious to moisture; sound and free from cracks, check, blisters, broken, extremities, or other imperfections; and must give a metallic ring when struck with a hammer. Pipe shall be bell and spigot pipe, unless otherwise specified. Pipe ends shall be square with the longitudinal axis and sockets shall be true, circular and concentric with the barrel of the pipe. The thickness of the shell shall be within the limits of permissible variation to dimension standards of the specifications of the National Clay Pipe Institute, <https://www.ncpi.org>, and to the applicable provisions of ASTM C700 for the size of pipe used. All pipe and special fittings shall comply with the applicable provisions of the VCP specifications of the National Clay Pipe Institute with respect to the hydrostatic pressure test, size, shape, three-edge bearing load test and all other requirements of said specifications, unless otherwise specified herein.

13-3 Identification Marks

All pipe or fittings shall be clearly marked with the name of the manufacturer or with a trademark of a size and type.

13-4 Causes for Pipe Rejection

The following imperfections in a pipe or special fitting will be considered injurious and cause for rejection:

A single crack in the barrel of the pipe extending through the entire thickness, regardless of the length of such crack. A single crack which extends through one-fifth of the barrel thickness and is over 3 inches long. Any surface fire crack which is more than 1/32-inch wide at its widest point.

Lumps, blisters, pit or flakes on the interior surface of a pipe or fittings.

When the bore or socket of the pipe varies from a true circle more than 3% of its nominal diameter.

When a pipe or fitting designated to be straight deviates from a straight line more than 1/16-inch per linear foot. The deviation shall be measured from a straight edge at a point midway between the ends of the pipe.

A point broken from either the socket or spigot end.

Tramp clays, grog or other foreign matter that have fused permanently to the exterior or interior surfaces of the pipe or fitting.

If, when placed in a vertical position, the pipes do not give a metallic ring when struck with a hammer.

13-5 Fittings

VCP fittings shall include branches of every type and stopper. Fittings shall be furnished and installed in conformance with these specifications.

13-6 Branches

Branches of type shown on the plans shall be furnished with connections of the sizes specified and shall be securely and completely fastened to the barrel of the pipe in the process of manufacture. This shall be accomplished by fusion during vitrification. In the case of pipe 15-inches or greater in diameter, fusion during vitrification will not be required, but if not fused, in addition to other fastening materials of approved quality, there shall be a reinforcing collar of cement mortar on the interior surface of the pipe. Tee branches shall have their axes perpendicular to the longitudinal axis of the pipe. Wye branches shall have their axes approximately 45 degrees (unless otherwise specified on the plans) to the longitudinal axis of the pipe measured from the socket end. All branches shall be of sufficient length to permit making a proper joint when the connection pipe is inserted in the branch socket.

The quality of VCP fittings and the joints for fittings shall conform to the applicable provisions of these specifications.

Installation of Branches: VCP wyes, tees and other types of branches shall be furnished and installed along with VCP sewer. Wyes shall be installed for all sewer house connections including foreseeable future sewer house connections. Tees shall be installed for chimneys where applicable. The longitudinal barrel of branch fitting to be placed in line and grade with the sewer mains shall be of the same diameter, quality and type as said sewer and conform to the applicable provisions set forth for pipe. Unless otherwise specified, the branch of wye fittings shall be inclined upward at an angle not greater than 45 degrees from a horizontal line. No wye or tee for sewer house connection branch shall be placed closer than 5 feet in the downstream side to the centerline of any structure.

13-7 Stoppers

Vitrified clay stoppers shall be 3/4-inch in thickness and shall have a factory-made plasticized polyvinyl chloride compound joint material cast and bonded to the pipe, such as Wedge-Lock, Speed Seal, or approved equal. The material shall be molded and cured to a uniform hardness and compressibility and form a tight compression coupling when assembled. The material used for the compression joint shall conform to ASTM C425.

Neoprene (synthetic rubber) stoppers shall be of the type manufactured by Pacific Clay Product, Interpace Corporation, or approved equal. The joint formed by the stopper and clay pipe shall be a tight compression coupling when assembled.

All joints for stoppers shall be adequate to withstand the internal pressure of the leakage and/or infiltration test; however, joints shall be made in such a manner that they may be removed without injury to the socket.

13-8 VCP At Manholes or Structures

A 2-foot VCP joint shall be placed at inlets and outlets to each manhole or structure to be constructed.

13-9 Sanitary “WYE” or “TEE” Branches

“Wye” or “tee” branches for 4-inch and 6-inch sewer laterals shall be furnished and installed of the type and size and at the locations required and as approved by the District. Branches are those fittings used to

fasten or affix a sewer lateral to a clay pipe sanitary sewer main. Where sewer house connections are not built, the branch socket shall be plugged with a stopper as per the Standard Details.

13-10 Installation

13-10a VCP Joints

All VCP and fittings shall comply with ASTM Standard C12 and furnished with mechanical compression joints equal to Wedge-Lock, as manufactured by Pacific Clay; Speed Seal, as manufactured by Interpace Corporation. The compression joint on the spigot and bell ends of the pipe shall be factory made of polyurethane or other approved resilient element bonded onto the outside of the spigot and the inside of the bell to the pipe and molded and cured to a uniform hardness and compressibility to form a tight compression coupling when assembled. Materials for compression joints shall conform to ASTM C425. An approved lubricant shall be used in the assembling of the pipe, and no further sealing element will be required. Joints shall be made watertight and root tight.

13-10b Laying VCP

Trenches shall be kept free of water during the laying operation. All pipe shall be laid without break, upgrade from structure to structure, with the socket ends of the pipe upgrade. Pipe shall be laid in such a manner as to form a close concentric joint with the adjoining pipe and prevent sudden offsets of the flow line. The interior of the sewer pipe shall be cleaned of all dirt and superfluous materials of all description as the work progresses. The provisions of Technical Specifications for Earthwork shall apply to the installation of the pipe.

13-10c Preventing Foreign Matter from Entering the Pipe

At times when the pipe laying is not in progress, the open end of the pipe shall be closed with a vermin-proof cap or plug and secured to prevent tampering by children. These provisions shall apply during the noon hour as well as overnight. In no event shall the sewers be used as drains for removing water which has infiltrated into the trenches.

13-11 Test for Leakage and Infiltration

It is the intent of these specifications that the completed sewer pipes of all types, along with manholes and other appurtenances, shall be watertight.

Each section of sewer between two successive manholes shall be tested for leakage and/or, at the option of the District, for infiltration. When groundwater is encountered, the infiltration test shall be made.

Even though a section may have previously passed the leakage or infiltration test, each section of sewer shall be tested subsequent to the last backfill, compaction operating in conjunction therewith, wherein, in the opinion of the District, heavy compaction equipment used in any of the operations may have damaged or affected the required watertight integrity of the pipe, structure and appurtenances. The Owner or his Contractor shall furnish all materials required for the tests and bear all costs in connection therewith. Tests shall be made in the presence of the District.

If the leakage and/or infiltration rate, as shown by the tests specified herein, is greater than the amount specified, the pipe joints shall be repaired or, if necessary, the pipe shall be removed and re-laid at the Owner's expense. The sewer will not be considered acceptable until the leakage and/or infiltration rate, as determined by test, is less than the allowable.

Prior to testing, all service laterals shall be installed and shall be tested simultaneously with the main line.

13-11a Leakage Test

The Owner may, at his option, air test or water test for leakage, except where the differences in elevation between the invert of the upper structure and the invert of the lower structure is more than 10 feet where the air test shall be made.

Water Test: Each section of sanitary sewer between two successive structures shall be tested by closing the lower end of the sewer to be tested and the inlet sewer of the upper structure with plugs or stoppers and filling the pipe and structure with water to a point 4 feet above the invert of the open sewer in the upper structure or to a height of 10 feet above the invert of the sewer in the lower structure, whichever gives the least hydrostatic pressure on the lower structure.

The total leakage shall be the decrease in volume of water in the upper structure. The leakage shall not exceed 0.1 gallons per minute per inch of nominal diameter of pipe per 1,000 feet of sewer pipe being tested. The length of house connections shall not be used in computing the length of sewer main being tested.

If the leakage, as shown by the test, is greater than allowed, the pipe shall be overhauled and, if necessary, replaced and re-laid until the joints and pipe shall hold satisfactorily under this test. All tests must be completed before the street or trench is resurfaced, unless otherwise determined by the District. The Owner or his Contractor shall furnish all labor and materials for making the tests required at his own expense.

Air Test Procedure: Each section of sewer between two successive manholes shall be tested by plugging all pipe outlets with suitable test plugs. Air shall be slowly added until the internal pressure is raised to 4.0 pounds per square inch gage (psig). The compressor used to add air to the pipe shall have a blowoff valve set at 5 psig to ensure that at no time the internal pressure in the pipe exceeds 5 psig. The internal pressure of 4 psig shall be maintained for at least two minutes to allow the air temperature to stabilize, after which the air supply shall be disconnected and the pressure allowed to decrease to 3.5 psig. The time required for the internal air pressure to drop from 3.5 psig to 2.5 psig shall be measured and the results compared with the values calculated using the following formula:

T = KL, Where T = time in seconds,
 L = distance between successive manholes in feet, and
 K = appropriate value from table below.

Pipe Diameter (inches)	K Value
8	.704
10	1.10
12	1.58
15	2.47
18	3.56
21	4.85
24	6.34
27	8.02
30	9.90
33	12.0
36	14.3
39	16.7
42	19.4

If the pressure drop from 3.5 psig to 2.5 psig occurs in less time than the calculated values, the pipe shall be overhauled and, if necessary, replaced and re-laid until the joints and pipe shall hold satisfactorily under this test.

13-11b Test for Infiltration

If, in the construction of a section of the sewer between structures, groundwater is encountered, the end of the sewer at the upper structure shall be closed sufficiently to prevent the entrance of water and pumping of groundwater shall be discontinued for at least three days after which the section shall be tested for infiltration. The infiltration shall not exceed 0.1 gallon per minute per inch of diameter per 1,000 feet of main line sewer being tested and does not include the length of house laterals entering that section. Where any infiltration in excess of this amount is discovered before completion and acceptance of the sewer, the sewer shall be immediately uncovered and the amount of infiltration reduced to a quantity within the specified amount of infiltration, before the sewer is accepted, at the expense of the Owner. Should, however, the infiltration be less than the specified amount, the Owner or his Contractor shall stop any individual leaks that may be observed when ordered to do so by the District. The Owner shall furnish all labor and materials for making the tests required at his own expense. All tests must be completed before street or trench is resurfaced, unless otherwise determined by the District.

13-11c Tests for Alignment and Grade, and Damaged or Defective Pipe in Place

After the pipe has been installed, tests for leakage and/or infiltration, backfilled to existing grade, manholes raised to grade and resurfaced, the pipe shall be “balled” from manhole to manhole with a sewer scrubbing ball of type and size to be approved by District.

After balling the pipe, perform the following:

1. “Mirror” straight sewers and inlet/outlet ends of curvilinear sewers. Perform balling and mirroring in the presence of the District’s Representative to test for alignment, grade, damaged or defective pipe in

place, or any other type of faulty installation. Should balling and mirroring indicate any faulty installation of the pipe, repairs or replacements shall be made at the Owner's expense.

2. Television inspection of the sewers. The Owner will make a video in digital format and any defects requiring correction will be noted. Upon completing the corrective work, notify the District; the affected portion of the pipeline system will be rerecorded. All costs for television inspection shall be made at the Owner's expense.

SECTION 14- POLYVINYL CHLORIDE SEWER PIPE AND FITTINGS

14-1 General

These specifications designate the requirements for furnishing, installation and testing of polyvinyl chloride (PVC) sewer pipe, fittings and appurtenances to be used for gravity flow sewer systems. Pipe shall not be stored on the roadways or parkways of residential streets for more than ten days or upon business streets for more than three days.

PVC pipe may be used on tract sewers not less than 8" or greater than 18" in diameter, and laterals not less than 4". Use of PVC pipe may be denied for certain industrial or commercial users based on their proposed sewage flows at the discretion of the District.

Excavation and backfill, including the pipe bedding, shall conform to provisions of the Technical Specifications for Earthwork and Standard S-2.

The maximum design deflection for plastic sewer pipe shall be 3%.

14-2 Materials

PVC pipe, fittings, couplings, and joints shall conform to the requirements of ASTM D3034, SDR 35, and shall have gasketed joints.

14-3 Identification Marks

All pipe, fittings, and couplings shall be clearly marked at an interval not to exceed 5 feet as follows:

- (1) Nominal pipe diameter.
- (2) PVC cell classification.
- (3) Company, plant, shift, ASTM, SDR, and date designation.
- (4) Service designation or legend.

For fittings and couplings, the SDR designation is not required.

14-4 Cell Classification

Pipe shall be made of PVC plastic having a cell classification of 12454 or 13364 as defined in ASTM D1784. The fittings shall be made of PVC plastic having a cell classification of 12454 or 13343 per ASTM D1784.

14-5 Test Requirements

Pipe, fittings, and couplings shall meet the requirements of ASTM D3034. During production of the pipe, the manufacturer shall perform the specified tests for each pipe marking. A certification by the manufacturer indicating compliance with specification requirements shall be delivered with the pipe. The certification shall include the test result data.

14-6 Gaskets

Gaskets shall conform to ASTM F477 and ASTM D3212. A single rubber gasket shall be installed in each bell end of a joint of pipe or fitting.

14-7 Fittings

PVC fittings shall include branches of every type and stopper. Fittings shall be furnished and installed in conformance with these specifications.

14-8 Branches

Branches shall be securely and completely fastened to the barrel of the fitting in the process of manufacture. Wye branches shall have their axes 45 degrees to the longitudinal axis of the pipe measured from the socket end. All branches shall terminate in sockets, and the barrel for the branch shall be of sufficient length to permit making a proper joint when the lateral pipe is inserted in the branch socket.

The material and quality of PVC fittings and the joints for fittings shall conform to the applicable provisions of these specifications.

Installation of Branches: PVC wyes, tees and other types of branches shall be furnished and installed along with PVC sewer. Wyes shall be installed for all sewer house connections including foreseeable future sewer house connections. The longitudinal barrel of branch fittings to be placed in line and grade with the sewer mains shall be of the same diameter, quality and type as said sewer. Installation, earthwork and bedding for branches shall conform to the applicable provisions set forth for mainline sewer pipe and the Technical Specifications for Sewer Laterals. The branch of wye fittings shall be inclined upward at an angle of 45 degrees from a horizontal line. No wye or tee for sewer laterals shall be placed closer than 5 feet in the downstream side to the centerline of any structure.

Where sewer laterals are not constructed, the wye or tee branch socket shall be plugged.

All joints for stoppers shall be adequate to withstand the internal pressure of the leakage and/or infiltration test; however, joints shall be made in such a manner that they may be removed without injury to the socket.

14-9 Installation

The bedding and pipe zone material for PVC sewer pipe shall be placed from 6-inches below the bottom to 12-inches over the top of the pipe and shall be pipe bedding aggregate conforming to the requirements of the Technical Specifications for Earthwork and the Standard Details.

All installation of PVC pipe shall be in conformance with ASTM D 2321 (latest edition). During the months of April thru October, PVC pipe exposed to the sun prior to laying shall be shaded from direct sun for at

least thirty (30) minutes before connection is made to manholes. Allowance shall also be made for the movement of pipe at house branch locations.

Any pipe which does not comply with the Specifications, is out of round, and has been rejected by the District, shall be removed from the jobsite and disposed of by the Owner.

14-9a Laying PVC Plastic Pipe

Trenches shall be kept free of water during the laying operation. All pipe shall be laid without break, upgrade from structure to structure, with the bell ends of the pipe upgrade. Pipe shall be laid to the line and grade given so as to form a close concentric joint with the adjoining pipe and prevent sudden offsets of the flow line. The interior of the sewer pipe shall be cleaned of all dirt and superfluous materials of all description as the work progresses.

14-9b Joining Systems

All pipes shall have a home mark on the spigot end to indicate proper penetration when the joint is made.

The socket and spigot configurations for the fittings and couplings shall be compatible to those used for the pipe.

Pipe shall be joined with elastomeric gasketed joints manufactured with a socket configuration which will preclude improper installation of the gasket and will ensure the gasket remains in place during the joining operation.

Joining of pipe shall be in accordance with the manufacturer's printed instructions, which shall be furnished to the District. The spigot end shall be inserted to the proper depth of the socket as indicated by the home mark.

14-9c Short Joints at Manholes and Structures

The minimum joint length of PVC placed at inlets and outlets to each manhole or structure to be constructed shall be twelve (12) inches.

14-10 Testing

Testing shall be performed in the presence of the District.

14-10a Test for Damaged or Defective Plastic Sewer Pipe in Place

Following the permanent and densification of backfill and prior to the placing of permanent pavement, all main line pipe shall be cleaned and then mandrelled to measure for obstructions (deflections, joint offsets, and lateral pipe intrusions). A rigid mandrel shall be pulled through the pipe by hand. The mandrel shall have a cross-section equivalent to a circle having a diameter of at least 95% of the average inside diameter for PVC pipe. The minimum length of the circular portion of the mandrel shall be equal to the nominal diameter of the pipe.

Obstructions encountered by the mandrel shall be corrected by the Owner.

All material, equipment, and labor to perform the test shall be provided by the Owner and/or Contractor.

14-10b Test for Leakage and Infiltration

It is the intent of these specifications that the completed sewer pipes of all types, along with manholes and other appurtenances, shall be watertight.

Each section of sewer between two successive manholes shall be tested for leakage and/or, at the option of the District, for infiltration. Where groundwater is encountered, the infiltration test shall be made.

Even though a section may have previously passed the leakage or infiltration test, each section of sewer shall be tested subsequent to the last backfill compacting operation in connection therewith, wherein, in the opinion of the District, heavy compaction equipment used in any of the operations may have damaged or affected the required watertight integrity of the pipe, structure and appurtenances. The Owner or his Contractor shall furnish all material required for the tests and bear all costs in connection therewith.

If the leakage and/or infiltration rate, as shown by the tests specified herein, is greater than the amount specified, the pipe joints shall be repaired or, if necessary, the pipe shall be removed and re-laid at the Owner's expense. The sewer will not be considered acceptable until the leakage and/or infiltration rate, as determined by test, is less than the allowable.

Prior to testing, all service laterals shall be installed and shall be tested simultaneously.

14-10c Leakage Test

The Owner may, at his option, air test or water test for leakage, except where the difference in elevation between the invert of the upper structure and the invert of the lower structure is more than 10 feet. In this instance, the air test shall be made.

Water Test Procedure: Each section of sanitary sewer between two successive structures shall be tested by closing the lower end of the sewer to be tested and the inlet sewer of the upper structure with plugs or stoppers and filling the pipe and structure with water to a point 4 feet above the invert of the open sewer in the upper structure or to a height of 10 feet above the invert of the sewer in the lower structure, whichever gives the least hydrostatic pressure on the lower structure.

The total leakage shall be the decrease in volume of water in the upper structure. The leakage shall not exceed 0.1 gallon per minute per inch of nominal diameter of pipe per 1,000 feet of sewer pipe being tested. The length of house connections shall not be used in computing the length of sewer main being tested.

If the leakage, as shown by the test, is greater than allowed, the pipe shall be overhauled and, if necessary, replaced and re-laid until the joints and pipe shall hold satisfactory under this test. All tests must be completed before the street or trench is resurfaced, unless otherwise determined by the District. The Owner or his Contractor shall furnish all labor and materials for making the tests required at his own expense.

Air Test Procedure: Each section of sewer between two successive manholes shall be tested by plugging all pipe outlets with suitable test plugs. Air shall be slowly added until the internal pressure is raised to 4.0 pounds per square inch gage (psig). The compressor used to add air to the pipe shall have a blowoff valve set at 5 psig to ensure that at no time the internal pressure in the pipe exceeds 5 psig. The internal pressure of 4 psig shall be maintained for at least two minutes to allow the air temperature to stabilize, after which the air supply shall be disconnected and the pressure allowed to decrease to 3.5 psig. The

time required for the internal air pressure to drop from 3.5 psig to 2.5 psig shall be measured and the results compared with the values calculated using the following formula:

- T = KL, Where T = time in seconds,
- L = distance between successive manholes in feet, and
- K = appropriate value from the following table.

Pipe Diameter (inches)	K Value
8	.704
10	1.10
12	1.58
14	2.15
16	2.81
18	3.56
20	5.99
24	6.34

If the pressure drop from 3.5 psig to 2.5 psig occurs in less time than the calculated values, the pipe shall be overhauled and, if necessary, replaced and relaid until the joints and pipe shall hold satisfactorily under this test.

14-10d Test for Infiltration

If, in the construction of a section of the sewer between structures, groundwater is encountered, the end of the sewer at the upper structure shall be closed sufficiently to prevent the entrance of water and pumping of groundwater shall be discontinued for at least three days after which the section shall be tested for infiltration. The infiltration shall not exceed 0.1 gallon per minute per inch of diameter per 1,000 feet of main line sewer being tested and does not include the length of house laterals entering that section. Where any infiltration in excess of this amount is discovered before completion and acceptance of the sewer, the sewer shall be immediately uncovered and the amount of infiltration reduced to a quantity within the specified amount of infiltration, before the sewer is accepted, at the expense of the Owner. Should, however, the infiltration be less than the specified amount, the Owner shall stop any individual leaks that may be observed when ordered to do so by the District. The Owner shall furnish all labor and materials for making the tests required at his own expense. All tests must be completed before street or trench is resurfaced, unless otherwise determined by the District.

14-10e Tests for Alignment and Grade, and Damaged or Defective Pipe in Place

After the pipe has been installed, tests for leakage and/or infiltration, backfilled to existing grade, manholes raised to grade and resurfaced, the pipe shall be “balled” from manhole to manhole with a sewer scrubbing ball of type and size to be approved by District.

After balling the pipe, perform the following:

1. “Mirror” straight sewers and inlet/outlet ends of curvilinear sewers. Perform balling and mirroring in the presence of the District to test for alignment, grade, damaged or defective pipe in place, or any other type of faulty installation. Should balling and mirroring indicate any faulty installation of the pipe, repairs or replacements shall be made at the Owner’s expense.
2. Perform television inspection of the sewers. A report and video in digital format of the sewers shall be submitted to the District. If deficiencies are observed, the Owner shall correct the deficiency and revideo the deficiency. Costs for television inspection shall be made at the Owner’s expense.

SECTION 15- CONNECTIONS TO EXISTING SEWER PIPE

15-1 Temporary Handling of Sewage

Certain work in connection with tying into existing sewers and manholes may require the temporary handling of sewage either by temporary bypass lines, pumping, bulkheading at low flows, or other means to be approved by the District. Sewage so diverted shall be handled in a manner so as not to create a public nuisance or health hazard. The Owner shall be responsible for any costs related to making these connections.

15-2 Remodeling Existing Manholes

Where an existing manhole base has to be reworked, provisions shall be made to keep pieces of concrete and debris out of the sewer. Where new flow-through channels have to be cut, they shall be cut so that the resulting section is smooth and conforms to the intended shape. Deviation from form and grade shall not be greater than 1/4-inch. Where holes are required in existing manhole walls for new or revamped connections, the Owner will be required to use coring-type equipment if, in the opinion of the District, the Contractor’s method of making holes will result in excessive damage to existing manholes. The size of the hole shall have a maximum dimension of 4-inches larger than the outside diameter of the pipe. The annular space shall be filled with dry-pack mortar.

15-3 Installation and Remodeling of Existing Manholes Along Existing HDPE Outfall Sewer

All manholes to be installed or reworked along the existing HDPE outfall sewer shall be coated with a chemical resistant coating. Coating shall be per the Technical Specifications for Chemical Resistant Coatings for Manholes.

Refer to Standard Details S-8 and S-9 for manhole installation along the HDPE outfall sewer.

Refer to Standard Detail S-10 for manhole rework of existing manhole along the outfall sewer.

15-4 Datum Verification

The Owner shall be responsible for verifying all existing elevations when making tie-ins regardless of data provided by District or District's Engineer.

SECTION 16- SEWER LATERALS

16-1 General

These specifications designate the requirements for furnishing and installation of sewer laterals.

Sewer laterals shall be constructed of the type and size and at the locations required and as approved by the District and in conformance with these specifications. The term "sewer lateral" is used in these specifications and on the plans to designate a branch sewer laid from a sanitary sewer main to a point on a street or public right-of-way or easement boundary from which sewer service to an individual building unit can be obtained through proper sewer extension by the property owner and shall be constructed according to the form, dimensions and details shown on the Standard Details.

16-2 Materials and Workmanship

16-2a Materials

Sewer laterals shall be of the same material as the main sewer line.

16-2b Size of Pipe

Sewer laterals shall be not less than 4 inches internal diameter. Actual size of building sewers larger than 4 inches shall be determined by fixture unit requirements as per the current edition of the Uniform Plumbing Code.

16-2c Depth of Pipe

Sewer laterals shall be placed at such depth to give a minimum of 48-inches of cover to the top of the bell at the property line or to edge of the easement. The minimum distance between the gutter flowline and the top of the sewer lateral shall be 3 feet.

16-3 Installation of Sewer Laterals

Sewer laterals and sanitary "wye" or "tee" branch fittings shall be of the diameter and of the form required and as approved by the District.

Each branch fitting shall have its barrel diameter equal to the diameter of the sanitary sewer main and the spur (or branch) diameter as necessary for connection to the sewer lateral. The spur pipe of branch fittings shall be inclined at an angle not exceeding 45 degrees from the horizontal and shall connect to the main sewer at an angle no greater than 45 degrees. Connections at 90 degrees are not permitted. All lateral connections shall be made in a manner that facilitates smooth flow and allows for future maintenance access. Laterals connected to manholes are not allowed.

New laterals connecting to new mains shall be supported with compacted clean sand, crushed rock or other material approved by the District in accordance with the Standard Details. New laterals connecting to existing mains shall be encased with Class A concrete.

All branch fittings that are to be left unconnected shall be plugged with a stopper equal in diameter to the outside of the pipe barrel and affixed securely in place. The stopper shall be of the same material used for the laterals.

Sewer laterals shall join to branch fittings at the sanitary sewer main as set forth above by eighth bends. All sewer laterals shall be plugged with a stopper in the socket at the last joint of said sewer laterals which shall be securely jointed and shall lie approximately at the public right-of-way boundary and/or property line.

16-3a Location of Sewer Laterals

The location of each sewer lateral shall be marked at its upper end by chiseling a letter "S" 1-1/2-inches high on the top of the curb. If the terminal point of the sewer lateral is more than 8 feet beyond the curb line or curb improvements do not exist, the Contractor or Owner shall furnish and install a wood stake at the end of the sewer lateral in conformance with the Standard Details.

16-3b Fitting at end of Sewer Laterals

Branch fittings shall be installed at the end of sewer laterals and unconnected ends shall be plugged with stoppers as provided herein.

SECTION 17- CONCRETE CONSTRUCTION

17-1 General

These specifications designate the requirements for furnishing and installation of concrete.

All concrete construction shall conform to the provisions of Sections 40 and 90 of the State Specifications, except as herein modified. Unless otherwise specified, all concrete shall be Class A.

17-2 Concrete

17-2a Class A

Class A concrete shall contain not less than six sacks of Portland cement per cubic yard and have a minimum compressive strength of 3,000 psi in 28 days.

17-2b Class B

Class B concrete shall contain not less than five sacks of Portland cement per cubic yard and have a minimum compressive strength of 2,500 psi in 28 days.

17-2c Class C

Class C concrete shall contain not less than four sacks of Portland cement per cubic yard and have a minimum compressive strength of 2,000 psi in 28 days.

17-3 Concrete Design and Materials

The District shall approve, prior to placing any concrete, the design of the mix proposed for use. Said mix design shall set forth weights of cement, sand, coarse aggregate and water to be used together with a grading analysis of sand and coarse aggregate. The source of supply of all materials entering into the mix shall also be given.

17-4 Reinforcing

Where reinforced concrete is required, reinforcing steel conforming to the applicable provisions of the latest edition of the State Specifications shall be furnished and installed.

SECTION 18- PRECAST CONCRETE MANHOLES

18-1 General

These specifications designate the requirements for furnishing and installation of concrete manholes.

Precast concrete sewer manholes shall be constructed in accordance with the design, size and details and at the locations required and as approved by the District. The manholes shall be constructed of precast eccentric manhole units in accordance with the Standard Details.

Manhole locations are fixed and cannot be moved to accommodate pipe manufacturing or laying. If necessary, special lengths will have to be provided to meet manhole location requirements.

18-2 Materials and Workmanship

18-2a Excavation and Backfill

Excavation and backfill shall be done in accordance with the Technical Specifications for Earthwork.

18-2b Concrete

All concrete used in the construction of manholes shall conform to the Technical Specifications for Concrete Construction.

18-2c Precast Manholes

Concrete for precast manhole units shall be Class A concrete. The precast cylinder units, the precast concrete eccentric cone, and grade rings shall meet the strength requirements for the latest edition of ASTM C478. Precast manholes shall be equal in all respects to those as manufactured by Utility Vault or centrifugally spun manhole units as manufactured by Ameron or approved equal. The minimum allowable steel shall be hoops of No. 4 wire to be cast into each unit at adequate places as a precautionary measure for handling. Each manhole section shall be set in a bed of grout to make a watertight joint and shall be

neatly pointed on the inside and shall be set perfectly plumb. Sections of various heights shall be used in order to bring the top of the manhole ring and cover to the required elevation.

The precast concrete manhole rings shall be joined with a minimum thickness of 1/2-inch of Portland cement grout or "Kent Seal".

Manhole Bases: Manhole bases shall be constructed of Class A concrete. Said concrete shall be formed and poured on undisturbed soil and/or on gravel subbases as required and as approved by the District. That portion of the base above the invert elevation of the sewer pipe shall be formed to provide a smooth channel section as shown on the Standard Details. The forms shall be checked and approved by the District for accuracy of dimensions and relative smoothness prior to pouring the base. Channels shall vary uniformly in size and shape from inlet to outlet, if required. The manhole base shall be poured as one monolithic pour. Precast manhole bases are not allowed.

18-2d Manhole Frames and Covers

Castings for frame and cover sets shall conform to the requirements for gray iron castings in the latest edition of ASTM A48 for Class No. 30 castings. Before leaving the foundry, all castings shall be thoroughly cleaned and subjected to a hammer inspection, after which they shall be dipped twice in a preparation of asphalt or coal tar and oil applied at a temperature of not less than 290°F., nor more than 310°F. and in such a manner as to form a firm and tenacious coating. Each cover shall be ground or otherwise so that it will fit in its frame without rocking, and frames and covers shall be match-marked in sets before shipping to the site. Covers shall have the word "NORS D SEWER" cast thereon as shown in the Standard Details. No other lettering on the topside will be permitted. Shop drawings of all manhole rings and covers shall be submitted to the District for approval.

Setting Manhole Frames and Covers: The elevations at which manhole frames and covers are to be set shall conform to the requirements set forth as required and as approved by the District. Where the cover is in existing pavement or in the traveled way of the existing road shoulder, it is to be placed flush with the existing surface. Where the structure is outside the limits of the traveled shoulder but not in the roadside ditch, it should be placed three (3) inches above the existing ground surface. Where the manhole cover falls in the existing roadside ditch or right-of-way, it is to be placed approximately 1-1/2 feet above the existing ground surface or as directed by the District and subject to the approval of the agency governing the right-of-way. Manhole frames shall be set at the required grade and shall be securely attached to the top precast manhole shaft unit with a grout bed and fillet as shown on the Standard Details. After the frames are securely set in the place provided herein, covers shall be installed and all necessary cleaning and scraping of foreign materials from the frames and covers shall be accomplished to ensure a fine satisfactory fit.

18-2e Drop Manholes

Drop manholes shall be constructed at locations specified by the District and in conformance with the Standard Details. Materials and construction of drop manholes shall conform in all respects to the applicable provisions of these specifications for standard precast manholes (including frames and covers), with modifications for the addition of drop inlets as set forth in the Standard Details. The inside diameter of the drop inlet pipe shall be the same diameter as the intercepted sewer, unless approved by the District.

18-2f Stubs at Manholes

Pipe stubs shall be furnished and installed at manholes at the locations required and as approved by the District. All stubs shall be plugged per Technical Specifications for the type of sewer pipe used in the construction. Stubs at manholes shall not exceed 5 feet in length.

18-2g Sewer Pipe and Fittings

All sewer pipe and fittings, including installation at manholes, shall conform to the provisions of the Technical Specifications for the type of sewer pipe used in the construction.

18-2h Resurfacing

Resurfacing of all excavations for construction of manholes shall conform to the provisions of the Technical Specifications for Removal and Resurfacing of Street Pavement and Surfaces.

18-2i Watertightness of Manholes

It is the intent of these specifications that manholes and appurtenances be watertight and free from infiltration. The adequacy of manholes and appurtenances as to watertightness shall be determined when ordered by the District by filling the manhole with water. When testing of the manhole is ordered, said test may be made in connection with the leakage test of the sanitary sewer. Any evidence of leakage as a result of testing shall be repaired to the satisfaction of the District at the sole expense of the Contractor or Owner.

18-2j Raising of Manholes within Surfaced Streets

The Owner shall be responsible for raising manhole frames and covers to finish grade as shown on the Standard Details within 30 days after pavement placement has been completed. Temporary coverings over manholes shall be provided to keep dirt and other material out of the sewer. Temporary covers shall be subject to approval by the District.

18-2k Manhole Steps

Manholes shall be installed without steps.

18-2l Manholes along the HDPE Outfall Sewer

Exposed concrete in manholes along the HDPE outfall sewer shall require a chemical-resistant coating. Refer to the Technical Specifications for Chemical Resistant Coatings for Manholes.

Refer to Standard Details S-8, S-9 and S-10 for manhole installation.

SECTION 19- CHEMICAL-RESISTANT COATINGS FOR MANHOLES

19-1 General

This section includes materials and installation of a chemical-resistant coating for exposed concrete in manholes to be installed along the existing HDPE outfall sewer and to re-worked existing manholes along the HDPE outfall sewer.

19-2 Materials

19-2a High-Build Epoxy for Entire Manhole

Solvent-free 100% solids, 2-part, ultra-high build epoxy coating system design for use in severe wastewater environments and certified to withstand H₂S concentration up to 1,200 ppm.

High-Build epoxy shall be Raven Series 405, Quadex Structure Guard, Neopoxy Series 5300, no equal.

Surface preparation and application shall be per manufacturer's recommendations. High build epoxy shall have a minimum thickness of ¼ -inch. Maximum thickness shall exceed manufacturer's recommendations. Epoxy applications shall be either spray or trowel on.

19-2b High-Build Epoxy for Manhole Bench and Channel

Solvent free, 100% Solid, high-build epoxy designed to provide corrosion protection in wastewater infrastructure and certified to withstand H₂S concentrations up to 1,200. Return to service time shall be less than 5 hours.

High-Build epoxy shall be Raven Series 405FS, Quadex Structure Guard RS, Neopoxy Series 5300, no equal.

Surface preparation and application shall be per manufacturer's recommendations. High build epoxy shall have a minimum thickness of ¾-inch and a maximum thickness not to exceed manufacturer's recommendations. Epoxy application shall be either spray or trowel on.

SECTION 20- SEWER CLEANOUTS

20-1 General

Sewer cleanouts shall be constructed at the locations shown on the Standard Details and/or at locations specified by the District.

20-2 Construction

Sewer cleanouts shall be encased with Class A Portland cement concrete (See Concrete Construction→ Section 17-2) to the form and dimensions as shown on the Standard Details. The base of the concrete encasement shall be poured against firm, undisturbed earth.

SECTION 21-TRAFFIC REGULATION

21-1 General

This section describes procedures for traffic regulation and temporary steel plate bridging during construction in public streets and highways.

21-1a Standard Specifications

Wherever reference is made to the State Specifications and Plans, such reference shall mean the latest edition of the State of California, California State Transportation Agency, Department of Transportation Standard Specifications and Plans, latest edition.

21-2 Vehicular Traffic

The Contractor shall always provide safe and continuous passage for pedestrian and vehicular traffic.

21-2a Traffic Control Plan

The Contractor shall submit, not less than 14 working days prior to start of construction operations, an alternate traffic plan to the City of Bakersfield, County of Kern, or local agency for approval. Preparation of any additional traffic control plans or detail that may be required during the work shall be the Owner's or Contractor's responsibility. No work shall begin involving or requiring alternate traffic control until a traffic control plan is approved by the appropriate authority.

21-2b Traffic Control Devices and Signs

Furnish, construct, maintain, and remove detours, road closures, traffic signal equipment, lights, signs, barricades, fences, K-rail, flares, solar-powered flashing arrow signs, miscellaneous traffic devices, flagmen, drainage facilities, paving, and such other items and services as are necessary to adequately safeguard the public from hazard and inconvenience. All such work shall comply with the ordinances, directives, and regulations of authorities with jurisdiction over the public roads in which the construction takes place and over which detoured traffic is routed by the Contractor. After devices have been installed, the Contractor shall, at his own expense, maintain and keep them in good repair and working order until no longer required. The Contractor shall also pay the cost of replacing such devices that are lost or damaged, to such an extent as to require replacement, regardless of the cause of such loss or damage.

21-2c Placement of Traffic Control Devices and Signs

The placement of construction signing, striping, barricades, and other traffic control devices used for handling traffic and public convenience shall conform to the latest edition of the State of California, Department of Transportation, "Manual on Uniform Traffic Control Devices".

21-3 Temporary Steel Plate Bridging, with a Nonskid Surface

When backfilling operations of an excavation in the traveled way, whether transverse or longitudinal, cannot be properly completed within a workday, provide steel plate bridging with a nonskid surface and shoring to preserve unobstructed traffic flow.

21-3a Plate Design

Design steel plate bridging for HS20-44 truck loading per Caltrans Bridge Design Specifications Manual. The Contractor may use standard steel plate with known coefficient of friction equal or exceeding 0.35.

21-4 Vehicular Traffic Control

Accomplish construction in phases by detouring traffic from its normal patterns along the route in approximately 1/2-mile intervals between major cross streets to form the construction zone. Restore traffic to normal patterns in each phase before proceeding to the next phase.

21-5 Pedestrian Traffic Control

Always maintain and delineate a minimum of one 4-foot-wide pedestrian walkway along each public street during construction. Always maintain existing pedestrian accesses at intersections. When existing crosswalks are blocked by construction activity, install signs directing pedestrian traffic to the nearest alternative crosswalk.

21-6 Access To Adjacent Properties

Always maintain reasonable access from public streets to adjacent properties during construction. Prior to restricting normal access from public streets to adjacent properties, notify each property owner or responsible person, informing him of the nature of the access restriction, the approximate duration of the restriction, and the best alternate access route for that particular property.

SECTION 22- REMOVAL AND RESURFACING OF STREET PAVEMENT AND SURFACES

22-1 General

Street pavement and surfaces shall be removed and replaced in all areas of construction where excavation is required and as approved by the District. Resurfacing of existing pavement and surfaces damaged or removed in connection with the construction of improvements shall conform to the provisions of permit issued by the State, City of Bakersfield, or County of Kern for the work within their right-of-way.

22-2 Earthwork

Earthwork shall conform to the provisions of the Technical Specifications for Earthwork.

22-3 Pavement Removal

Street pavement or existing road surfacing shall be removed within the limits of all construction excavations prior to proceeding with excavation operations of any nature. Surplus material shall be removed as provided in the Technical Specifications for Earthwork. Prior to removal of existing surfacing, pavement cuts shall be made neat and straight along both sides of the trench and parallel to the alignment of the pipe to provide an unfractured and level pavement joint for bonding existing surfacing with pavement replacement. Where large irregular surfaces are removed, such trimming or cutting as hereinafter provided shall be parallel with roadway centerline or at right angles to the same. All cut edges shall provide clean, solid, vertical faces free from all loose material.

22-3a Portland Cement Concrete Surfaces

Concrete pavement, including cross-gutters, curbs and gutters, sidewalks, driveways and concrete surfaces of whatever nature shall be saw cut to a minimum depth of 1-1/2-inches prior to removal. Said saw cut shall be made at a point approximately 1 foot beyond the edge of the trench and/or excavation.

22-3b Asphalt Concrete Pavement

Streets and alleys surfaced with asphalt concrete pavement shall be initially cut by means of pneumatic pavement cutters or other approved equipment at the limits of the trench and/or excavation prior to removal of surfacing. After backfilling the excavation, asphalt concrete pavement shall be saw cut to a minimum depth of 2 inches at a point not less than 9 inches outside the limits of excavation or the previous pavement cut (made by pneumatic tools), whichever limits are the greater. The additional surfacing so cut shall be removed and disposed of prior to resurfacing.

22-4 Resurfacing

In all streets or alleys in which the surface is removed, broken or damaged by equipment or in which the ground has caved in or settled due to the installation of the improvements, the surface shall be restored to the original grade and crown section. Where the street has been improved with roadway surface, base material, curb, sidewalk, or gutter, trenches or damaged sections shall be restored with the type of improvement conforming to that which existed prior to the work. Prior to resurfacing, the existing surfacing shall be removed as provided above. All broken and jagged edges of the trench edge shall be straight. If during the initial removal of the existing pavement a method of removal was used which disturbed the adjoining pavement or if during general construction the adjacent pavement was disturbed, then this adjoining pavement must also be removed and replaced. Disturbed or undermined cement treated base shall be removed and replaced with its equivalent aggregate base, and asphalt concrete paving above the cement treated base shall be sawed in a straight line and replaced in kind. Where irregular surfaces are to be surfaced, existing pavement shall be cut parallel to the alignment of the pipe or to the centerline of the street. End cuts shall be perpendicular to the street alignment.

All work shall match the appearance of the existing improvements and finished pavement shall not deviate from existing grade by more than 0.01 foot in 12 feet and shall be free from ruts, depressions, and irregularities. Where the trench line is approximately parallel with the traveled way, the pavement shall be brought to the final grade with a Barber-Green paving machine or approved equal. The resulting edge of contact between the new and existing pavement of each side shall parallel the existing trench and be a straight and neat join line. New pavement shall not lap over existing pavement.

In the event that no pavement structural section requirements are specified by any other agency, the minimum pavement section for patches shall be 4 inches of asphalt pavement (Type B, 1/2-inch minimum aggregate, PG 64-10 asphalt) over 8 inches of Class 2 A.B. aggregate base compacted to 95 percent (95%) relative compaction per latest edition of State of California, California State Transportation Agency, Department of Transportation, Standard Specifications.

22-5 Temporary Resurfacing

In the event that it is necessary to construct a temporary patch, the materials used shall be approved by the District or other agency having jurisdiction. A permanent patch shall be constructed as soon as practical.

SECTION 23- STEEL CASING PIPE

23-1 General

These specifications designate the requirements for furnishing and installation of steel casing pipe.

All work shall conform to the specifications and requirements of the State of California, Kern County, City of Bakersfield, or other agency having jurisdiction. All necessary permits for the casing pipe installation must be obtained and copies submitted to the District prior to start of the work.

23-2 Materials

Steel casing pipe shall be butt welded of sheets conforming to ASTM Specifications A1011/A1011M or of plate conforming to ASTM Specification A283, copper bearing. All field joints also shall be butt welded full circumference or by other means approved by the District. Use of a jacking band to reinforce the end of the pipe receiving the jacking thrust will be required. Wall thickness of casing pipe shall be a minimum of 3/8-inch and the diameter shall be of the minimum size required and as approved by the District.

23-3 Installation

Steel casing pipe of the minimum sizes and thicknesses shown in the Standard Details shall be installed in place by jacking and/or boring methods, without the use of water or air.

The carrier pipeline shall be installed in the casing as shown in the Standard Details. The annular space between the casing and the carrier pipe shall be filled with sand. Sand shall be free from foreign materials such as rocks, sticks, vegetation, etc.

23-4 EARTHWORK AND RESURFACING

Earthwork and resurfacing shall conform respectively to the provisions for the Technical Specifications for Earthwork and Removal and Resurfacing of Street Pavement and Surfaces.

SECTION 24- USE OF COMPLETED FACILITIES

The District shall have the right upon ten (10) days written notice to the Owner and his Surety to take possession of and use any completed or partially completed portion of the work notwithstanding that the time for completing the entire work may not have expired, but such taking possession and use and assumption of maintenance of any portion of the work shall not be deemed an acceptance of any work. It is the intent of this section to provide for the District placing into operation portions of the facilities as the work progresses.

When any section of the improvements has been completed in all respects, except for trench resurfacing, the District may so notify the Owner and his Surety in writing as provided herein. After such notice has been given, the District shall have the right to place such section of the facility into service and to operate same. The Owner will be relieved of the duty of maintaining and protecting said portion of the work except for any resurfacing, if required. When resurfacing is not required, the Owner shall be relieved of the responsibility and duty of maintaining and protecting portions of the roadway only after receiving written notice from the District.

However, nothing in this section shall be construed as relieving the Owner of the full responsibility for making good defective work or materials as specified in the General Provisions.

SECTION 25- INSPECTION OF WORK

All work shall be subject to inspection and shall be left open and uncovered until the installation is approved by the District. If the work has been backfilled prior to District inspection, the District may require the work to be exposed, at the Owner's expense, for inspection or perform a video inspection for a fee.

The District shall at all times have access to the work during construction and shall be furnished with every reasonable facility for ascertaining full knowledge respecting the progress, workmanship and character of materials used and employed in the work.

The Owner shall submit a schedule to the District outlining the proposed construction operation including the hours of work. If any changes in the project schedule or hours of work are made, the Owner shall give at least two working days written notice to the District so that proper inspection may be provided.

No pipe, fittings or other materials shall be installed until inspected and approved by the District. All installations which are to be backfilled shall be inspected and approved by the District prior to backfilling and due notice shall be given to the District in advance of backfilling so that proper inspection may be provided.

The inspection of the work shall not relieve the Owner of any of his obligations to complete the work as prescribed by the District Specifications. Defective work shall be made good and unsuitable materials may be rejected notwithstanding the fact that such defective work and unsuitable materials have been previously overlooked by the District and accepted.

The District shall have the authority to suspend the work wholly or in part for such time as it may deem necessary due to the failure to perform any provisions of District Specifications. The work shall be resumed when methods or defective work are corrected as ordered or approved in writing by the District. Costs associated with the suspension of work shall be at the owner's expense.

The Owner shall bear all costs of construction inspection. The Owner shall also bear the cost of traffic regulations lawfully exacted by the Federal Government, the State of California, or County or City during the time of performing work affecting the property of said Government, State, County or City.

SECTION 26- CLEAN-UP

During the progress of the work, the premises shall be kept free of any accumulation of rubbish and debris. Upon completion of the work and before final acceptance of the completed facility by the District, all unused materials, rubbish, concrete forms, surplus excavated material and other materials or equipment shall be removed from the work area.

If during the progress of the work any improvements, such as, fences, lawns, shrubs or other vegetation, whether on private or public property are damaged, they shall be restored to a condition equivalent to that which existed before work started before acceptance of the completed facilities by the District.

Prior to the acceptance of any sewer line by the District, the contractor shall clean all lines with a Wayne-type sewer cleaning ball under hydrostatic pressure. Any stoppage, dirt or foreign matter shall be removed from the lines. All cleaning and testing of sewer lines shall take place after all construction work is completed, up to but not including, the final paving. The system will be inspected after final paving is completed and any damage to the system during final paving and cleanup will be corrected before approval.

SECTION 27- GENERAL REQUIREMENTS FOR SEWER LIFT STATIONS

The District's 2023 Sewer Master Plan identifies the locations and projected flow capacity requirements of several interceptor sewers and sewer lift stations that are required to serve the District's Service Area as the area develops. The developer's engineer shall work with the District in preparing the plans and specifications for the lift stations identified in the Sewer Master Plan as well as other lift stations that may be required to serve development. The plans and specifications prepared by the developer's engineer shall be subject to the review and approval of both District staff and the District's Engineer. These sewer lift stations shall have the following minimum features as described in paragraphs A through F below. Additional features, requirements and/or specifications for the sewer lift station may be needed as required by the District.

27-1 General Pump Requirements

1. A minimum of three (3) pumps shall be installed in a single wet well (two duty pumps and one standby) and shall conform to the following requirements:
 - Each of the wet well pumps shall be:
 - Submersible.
 - Fitted with impellers capable of passing debris and rags without clogging.
 - Rail mounted.
 - Vaughn Chopper Pump or District approved alternate. The minimum motor horsepower shall not be less than 5hp unless otherwise approved by the District.
 - Connected to discharge piping using elbow disconnect which is to be supplied with pump and installed per manufacturer's recommendations.
2. Pumps shall be removable from ground level through use of a lifting chain and guide rail. Lifting chain and guide rail to be supplied with pump and shall be installed per manufacturer's recommendations.
3. An additional spare pump shall be provided.

27-2 Sewer Lift Station Site Requirements

1. Sewer lift stations shall be located outside street right of way in an easement dedicated to District for a lift station. Lift station sites are to be located as far away from schools, churches, playgrounds or other public and private buildings and heavily used areas as possible. Sewer Lift Station sites shall not be located:
 - In privately controlled areas such as golf courses.
 - Directly adjacent to private homes.
 - Directly under high voltage electric lines.
 - On sidewalks, driveways, alleys or in the street.
2. Sewer Lift Station sites shall have the following features:
 - Site shall be enclosed by a 6 foot chain link fence with privacy slats and topped with three strands of barbed wire.
 - Site interior shall be surfaced with a minimum of 4" of ¾" gravel.
 - Site shall have a 16' wide gated opening with secure locking mechanism to provide access for equipment and vehicles. This entrance must be easily accessible by District maintenance vehicles at all times and shall not open into high traffic areas.
 - Site shall have ample space for easy vehicle and equipment maneuverability. Minimum site size is 10,000 sq.ft. with a minimum width of 80 feet.
 - A fresh water supply and hose bib near the wet well for maintenance.
 - Phone and internet service to control panel.
 - Adequate lighting with switches accessible upon entering site.

27-3 Lift Station Wet well Requirements

1. The sewer lift station wet well shall have the following features:
 - The high water level in the wet well shall not be less than 3 inches below the invert of the lowest sewer main entering the wet well.
 - The active storage in the wet well (i.e. between the low water level and high water level shall be not less than 10 minutes of design peak flow.
 - Wet well shall be constructed using 96-inch diameter concrete reinforced concrete pipe sections manufactured to meet ASTM Standards C76, C443, and C655. The lower wet well section shall be a minimum of six (6) feet in length. Interior concrete surfaces shall be coated with an approved coating system prior to the installation of pumps (see CHEMICAL-RESISTANT COATINGS FOR MANHOLES). The discharge connection mating surface shall be kept clean and free of all coating.
 - Wet well shall be equipped with a stainless steel-fitted aluminum constructed access frame and cover rated for an H20 loading and shall have 3" clear from largest pump dimension which will allow for easy lifting out of pump and motor assembly. Cover shall be equipped with pump compatible guide rails support brackets with pump lifting chain hook; a blower switch to turn on blower when cover is opened; secondary safety doors, and a locking mechanism. Access cover shall be Halliday Series S2S or approved equal with fall protection grating panel.
 - A pump davit crane shall be mounted on the wet well. Provide Thern or approved equal.
 - Wet well deck shall have a wide concrete pad inclined slightly so waste water and debris can be washed back into the well easily after maintenance operations.

- Wet well shall be mechanically vented to prevent odors from reaching adjacent properties. Use Peace Maker model or approved equal.
- All exposed areas of the wet well not protected by other coatings shall be covered with 300M bitumastic.
- Primary pump control shall be by an ultrasonic level transmitter system. A completely redundant back up pump control float system shall also be provided. Transmitters and floats shall be located so that they are accessible without entering the wet well.
- Wet well level shall be monitored and controlled at a minimum of five points: Lead Pump On, Lag Pump On, High Alarm Level, Lag Pump Off, Lead Pump Off.
- Domestic water supply required onsite, shall provide a reduced pressure backflow preventer rated for 175 psi working pressure and a temperature range of 32–140°F, suitable for inline servicing. The assembly shall include two independently operating spring-loaded “Y” pattern check valves and a hydraulically dependent differential relief valve. Valve bodies and covers shall be lead-free cast copper silicon alloy with reversible seat discs and a removable relief valve seat ring for maintenance without removing the valve from the line. The device shall conform to AWWA C511 for a 1-inch service or approved equal.
- Wet Well Water Stops: All cored openings in the wet well wall shall be sealed with water stops secured by stainless steel bands and non-shrink grout
- Concrete Strength: The minimum ultimate (28 days) compressive strength of all structural concrete shall be 4000 psi.
- Concrete Mix: Structural concrete must contain at least 675 pounds of cementitious material per cubic yard of concrete. The maximum size of aggregate shall be one and one-half (1 ½) inches.
- Slump: The amount of water used for mixing (including free moisture carried by the aggregate) shall not exceed the maximum necessary to produce a four (4) inch slump as determined by ASTM test method C143.
- Defective Concrete: Concrete not meeting the minimum strength requirement, not formed as indicated, not true to intended alignment, which has large voids or rock pockets, which has wood or other debris embedded which has a surface deviation greater than one-eighth (1/8) inch in 10'-0", or does not fully conform to the specifications shall be deemed defective, and if so directed by the Engineer, shall be removed and replaced with concrete complying with the drawings and specifications.
- Form work: Earthen forms for exterior concrete surfaces shall be allowed only upon approval by the Engineer. The acceptability of the earthen forms shall be solely decided upon by the Engineer.
- Finishes on Walking Surfaces: The contractor shall give a monolithic finish to the walking surfaces at all concrete floors and slabs within and adjacent to the structures. All concrete surfaces to be so finished shall be thoroughly worked, brought to a uniform smooth finish and given a final brush finish.
- Non-Shrink Grout and Dry-pack: Non-shrink grout shall conform to the following proportions:
 - Portland Cement..... 1 Part by Wt.
 - Sand (100% Passing #8 Sieve)1 Part by Wt.
 - Water..... 4 ½ -5 ½ gal./sack cement
 - Sika "intraplast" N Admixture.....1 % by Wt. Of cement
- Dry-pack shall be composed as for grout except that only enough water shall be added to wet the mixture (no free water and no slump). Dry-pack shall be tamped into place and cured as specified for concrete in this section. Contractor shall not use non-shrink grout or dry-pack that has been mixed longer than 30 minutes. No re-tamping shall be allowed.
- Finishes on Walking Surfaces: The contractor shall give a monolithic finish to the walking surfaces at all concrete floors and slabs within and adjacent to the structures. All concrete surfaces to be

so finished shall be thoroughly worked, brought to a uniform smooth finish and given a final brush finish.

- Curing: All newly placed concrete shall be kept moist for a minimum of the first seven (7) days after the concrete has been placed.

27-4 Control Cabinet / Panel Requirements

1. Lift Station Control Cabinet/Panel shall be weatherproof, rainproof, and lockable. The entire control panel shall be UNDERWRITERS LABORATORY LISTED and furnished with a UL LABEL. The Control Cabinet/Panel shall be constructed of stainless steel with the following features:
 - Control panel, wiring, hardware, software, etc. shall comply with the most recent District SCADA master plan.
 - Shall be free standing and mounted on a reinforced concrete base.
 - Each component shall be factory mounted, wired, inspected, and tested. A wiring diagram shall be enclosed in the panel and all components shall be permanently identified.
 - Shall be covered by a District approved shade canopy, with a weatherproof overhead light and switch. Large lift stations may require a control building at the discretion of the District.
 - Controller to be mounted at eye level. Control system shall provide for complete automatic control of operations with rotation of lead, lag, and standby pumps and shall have a transducer level control system. A spare level transducer shall be provided.
 - Weatherproof standby power receptacle allowing for connection of District's portable generator (200A, 3 phase, 480V, 5 Pole). Keep area for portable generator clear.
 - Control/power cabinet shall open towards wet well.
 - Control/power cabinet shall have ventilation and fan for warm weather and a heater for cool weather.
 - Automatic alternator.
 - Run time meter for each pump.
 - Hands-off-auto switch for each pump.
 - Run lights, green for each pump.
 - High water alarm light, red, on top of cabinet/panel.
 - Alarms for high-high, high, low, low-low, rate of change, and instrument fail.
 - Alarm silence and reset switches.
 - Provide motor starter overload reset operators on the dead front door.
 - Provide a 750 watt duplex convenience receptacle with ground fault interrupter installed on the dead front door.
 - Provide a separate lockable stainless steel connection cabinet conforming to NEMA 3R standard between the wet well and the control cabinet with a quick disconnect connectors for the pumps, ultrasonic level transmitter, and redundant float system.
 - Provide a covered, securable channel for cables between the connection cabinet and the wet well as in Romtec installations.

27-5 Control System Operation

- The control system shall provide total automatic control for two (2)
- motor driven pumps operating on 480 volts, 3 phase service. The wet
- well level shall be monitored and controlled as follows:
- Level 5- High Level
- Level 4- Start Lag Pump
- Level 3- Start Lead Pump
- Level 2- Stop Lag Pump
- Level 1- Stop Lead Pump
- Contingent upon the wet well level, the level control system shall cause the liquid level indicator/controller to energize the appropriate control contacts.
- Upon rising wet well level, the lead pump start contact shall energize a relay in the pump logic controller to start the lead pump. If the level continues to rise to the lag pump start point, the controller shall start the lag pump, allowing both pumps to operate simultaneously until the lag pump stop level is reached. The lead pump shall then continue to run until the lead pump stop level is reached, after which the system shall automatically alternate lead-lag pump designation on the next cycle. A high-level contact shall activate the alarm system, with provisions allowing the owner to select the alarm activation level and configure either independent or common start/stop control for both pumps.
- The logic panel shall include selector switches, pump run and power status LEDs, alarm indicators and silence/reset pushbuttons, and two non-resettable running-time meters. The complete assembly shall be corrosion-resistant, clearly labeled, and factory pre-wired for reliable duplex pump operation and alarm control.

27-6 Emergency Power Generator

1. At the discretion of the District, a sewer Lift Station may require a permanent emergency power generator that conforms to the following requirements:
 - Generator location must meet District's approval.
 - Base fuel tank shall be of adequate size for 12-hour full-load run time.
 - No two-cycle engines are allowed.
 - Generator must be equipped with:
 - A critical grade muffler, 75 dBA max at 25 feet.
 - A 2-5/16" heavy-duty trailer hitch and two safety chains rated to exceed the GVWR of the completed unit.
 - A solar charge panel of adequate size to maintain a fully charged battery when not in use.
 - Engine shall meet all current California Air Resources Board and San Joaquin Valley Air Pollution Control District standards. All permits required for operation will be the responsibility of the supplier.
 - Provide operations training to District staff and three complete copies of the generator's operations and maintenance manual.
 - A power monitor relay system shall be installed and connected to the logic chassis. The power monitor relay system shall continuously monitor incoming utility power for abnormal electrical conditions. Upon detection of any of the specified fault conditions, the power monitor relay shall automatically disconnect the facility from the normal (utility) power source, initiate the automatic transfer switch (ATS) sequence, and signal the emergency generator to start and assume the load.

Once generator voltage and frequency are stabilized, the ATS shall transfer control and motor power to the emergency generator source, and the logic chassis shall restart the pump motors in accordance with programmed start-delay sequencing.

- During fault conditions, the system shall illuminate a red LED indicator on the logic chassis. When normal utility power is restored and verified stable, the power monitor relay system shall automatically retransfer the load to the normal source and shut down the generator after a suitable cool-down period. The power monitor relay shall be activated in the event that any of the following conditions occur:
 - Phase loss (single phasing): when any one of the three-line voltages drops to 83 percent or less of nominal
 - Phase reversal (sequence): when improper phase sequence is applied to the equipment.
 - Low voltage (brownout): when all three-line voltages drop to 90 percent or less of nominal.

27-7 Miscellaneous Lift Station Requirements

1. Sewer lift stations shall conform to the following miscellaneous requirements:
 - All lift station steel fittings, brackets, cables, anchors, nuts, bolts, etc. shall be type 316 stainless steel.
 - All non 316 stainless steel discharge pipe shall be coated with 300M bitumastic.
 - The pump number shall be painted on each discharge pipe in both the wet well and valve vault in a manner clearly visible from above in contrasting colors.
 - All pipes shall have a watertight seal through the walls of the wet well and vault.
 - Pump discharge piping shall be routed into a valve vault equipped with eccentric plug valves and spring loaded check valves (DeZurik, Clow, Kennedy or equal) for each discharge line. Valve vault shall drain into wet well via “P-trap” type drain. See Standard Drawing S-16 for a schematic of the general arrangement of the discharge piping.
 - Where the lift station discharges to a force main, the force main shall be a dual force main system. Each individual force main shall be capable of conveying the peak flow from the lift station per the requirements set forth in Section 3-2.
 - Valve vault cover shall have a minimum of clear opening as approved by the District and be rated for an H2O loading and include a locking mechanism. Halliday Series W2S or approved equal with fall protection grating panel as required based on vault depth. An access ladder shall be mounted in the vault.
 - Furnish and apply to the satisfaction of the District, protective paint in colors as approved by the District. All exposed interior and exterior metal surfaces, except aluminum, galvanized steel, stainless steel and chrome plated metal, shall be coated. All paint shall be delivered in original containers and shall be applied in strict accordance with the recommendations of the manufacturer. All uncoated surfaces in the valve vault shall be primed and triple coated with epoxy coating.
 - The manhole immediately upstream of lift station shall be located within the limits of the lift station easement and within the fencing surrounding the lift station.
 - A sewer pressure cleanout with the ability to connect to a 6” portable pump shall be constructed on at least 2 of the force main lines downstream of the check valves. See Standard Drawing S-16.
 - PVC force mains shall conform to AWWA C900, Class 150 minimum. Ductile iron (DI) piping shall conform to AWWA C151. Fittings shall conform to AWWA C110, minimum 250 psi pressure rating. Ductile iron pipe shall be epoxy lined and coated as recommended by the pipe manufacturer for raw wastewater service. Appropriate joint restraints shall be provided.

- The complete sewer lift station will be subject to a commissioning and start up testing program as established by the District. Trained factory personnel shall provide operational training for District personnel and repair and maintenance services throughout the guarantee period. Lift Station operations and notifications will be in accordance with the District's current SCADA master plan.

Part 3- PLATES (DRAWINGS)

Plate 1- Standard Sewer Notes (S-1)

<u>SEWER NOTES</u>				
1.	THE SEWER FACILITIES TO BE DEDICATED TO THE N.O.R.S.D. SHALL BE CONSTRUCTED IN ACCORDANCE WITH THE STANDARD SPECIFICATIONS OF THE N.O.R.S.D.			
2.	THE N.O.R.S.D. SHALL BE NOTIFIED AT LEAST TWO (2) WORKING DAYS PRIOR TO START OF CONSTRUCTION. TELEPHONE (661) 399-6411.			
3.	THE CONSTRUCTION PLANS MUST BE APPROVED BY THE N.O.R.S.D. PRIOR TO THE START OF ANY SEWER CONSTRUCTION. TWO (2) SETS OF APPROVED PLANS SHALL BE FURNISHED TO N.O.R.S.D. AND ONE (1) SET OF THE SAME TO THE DISTRICT'S ENGINEER. PRIOR TO DISTRICT APPROVAL, THE PLANS MUST BE SIGNED BY A CALIFORNIA REGISTERED CIVIL ENGINEER.			
4.	PRIOR TO ACCEPTANCE OF THE SEWER FACILITIES, ALL NECESSARY EASEMENT DOCUMENTS SHALL BE PROPERLY EXECUTED AND RECORDED. TWO (2) COPIES EACH OF THE RECORDED DOCUMENTS SHALL BE FURNISHED TO N.O.R.S.D.			
5.	PRIOR TO THE ACCEPTANCE OF THE SEWER FACILITIES, ALL PIPING SHALL BE TESTED FOR LEAKAGE AND INFILTRATION. ALL PIPING SHALL BE VIDEO INSPECTED.			
6.	THE MANHOLE FRAME AND COVER AND CONCRETE SUPPORT FOR MANHOLES SHALL BE RAISED AND CONSTRUCTED TO FINISHED PAVED GRADE AFTER THE PAVING OPERATION IS COMPLETED. THE RING SECTION SHALL NOT BE MORE THAN 18" FROM THE CONE. THE COMPLETE SEWER SYSTEM SHALL BE COMPLETELY CLEAN PRIOR TO ACCEPTANCE.			
7.	WORK IN THE STATE OF CALIFORNIA, THE COUNTY OF KERN, OR THE CITY OF BAKERSFIELD RIGHTS-OF-WAY SHALL BE DONE IN ACCORDANCE WITH THE APPROPRIATE ENCROACHMENT PERMITS.			
8.	THE SEWER SYSTEM, INCLUDING LATERALS, SHALL BE HYDROSTATIC WATER OR AIR TESTED, AFTER ALL UNDERGROUND UTILITIES ARE CONSTRUCTED, AND PRIOR TO PLACING STREET PAVEMENT.			
9.	EXISTING SEWER LOCATION AND FLOWLINE SHALL BE VERIFIED IN THE FIELD BY THE CONTRACTOR BEFORE START OF CONSTRUCTION. THE DISTRICT SHALL BE NOTIFIED IMMEDIATELY OF ANY DISCREPANCIES.			
10.	ONE COMPLETE SET OF RECORD DRAWINGS (IN BOTH MYLAR AND AUTOCAD FORMAT) SHALL BE FURNISHED TO THE DISTRICT ON COMPLETION OF CONSTRUCTION.			
11.	THE SEWER DESIGN ASSUMES SINGLE FAMILY RESIDENCES (SFR) WILL BE CONSTRUCTED ON ALL R1 ZONED LOTS. SHOULD DEVELOPERS AND/OR BUILDERS PROPOSE TO CONSTRUCT MULTIFAMILY UNITS (WHICH INCLUDES SFR PLUS ADUS) ON LOT(S), AN ENGINEERING ANALYSIS WILL BE REQUIRED TO DEMONSTRATE THAT THE SEWER DESIGN IS ADEQUATE FOR THIS ADDITIONAL HOUSING AND MEETS NORTH OF RIVER SANITARY DISTRICT STANDARDS.			
NORTH OF RIVER SANITARY DISTRICT No. 1				
STANDARD SEWER NOTES				
3/26	REVISED	AECOM	DATE DRAWN	SHEET NO.
2/10	REVISED		10/04	S-1
DATE	REVISION			

Plate 2- Sewer Pipe Bedding and Backfill Details (S-2)

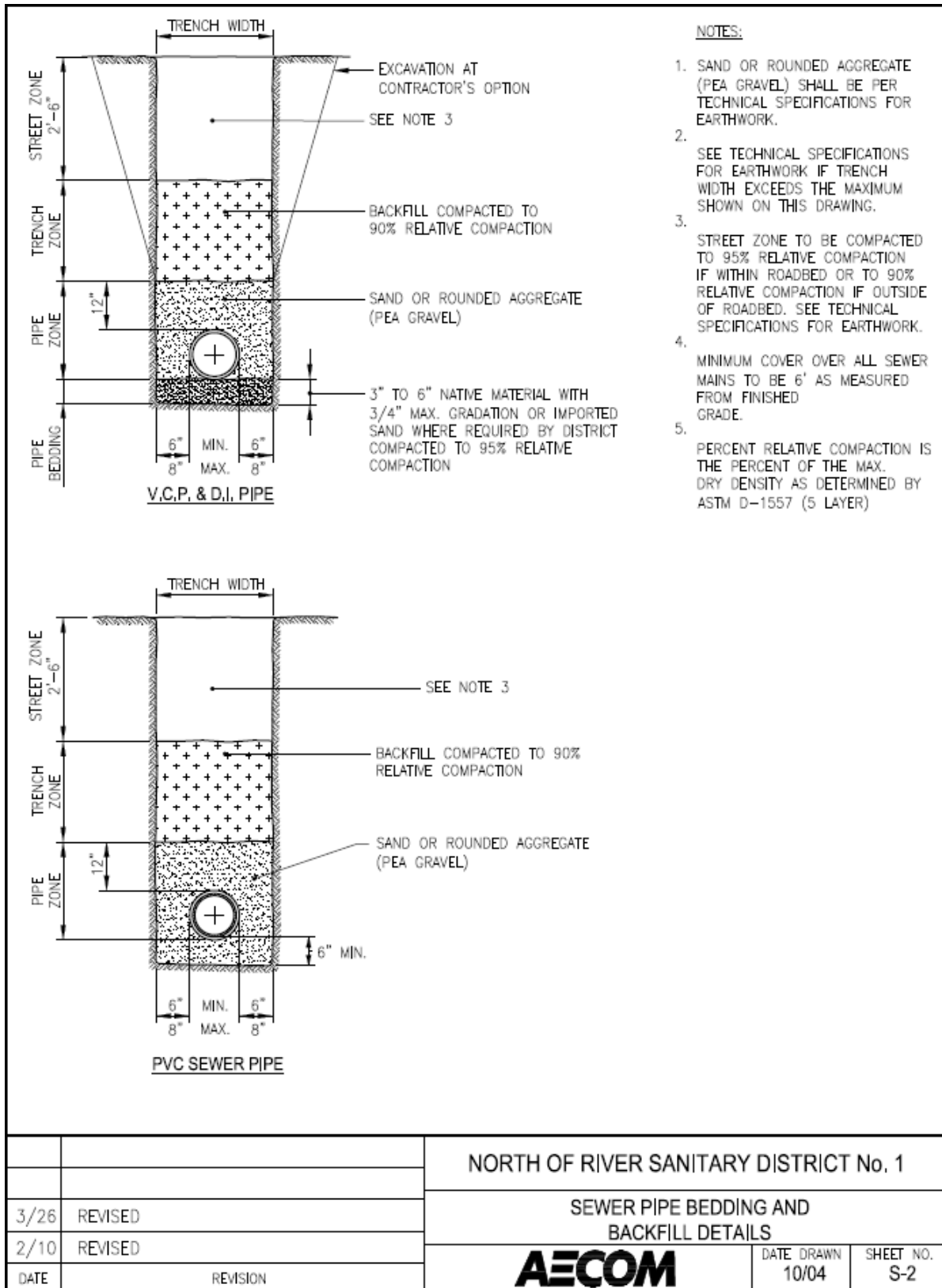
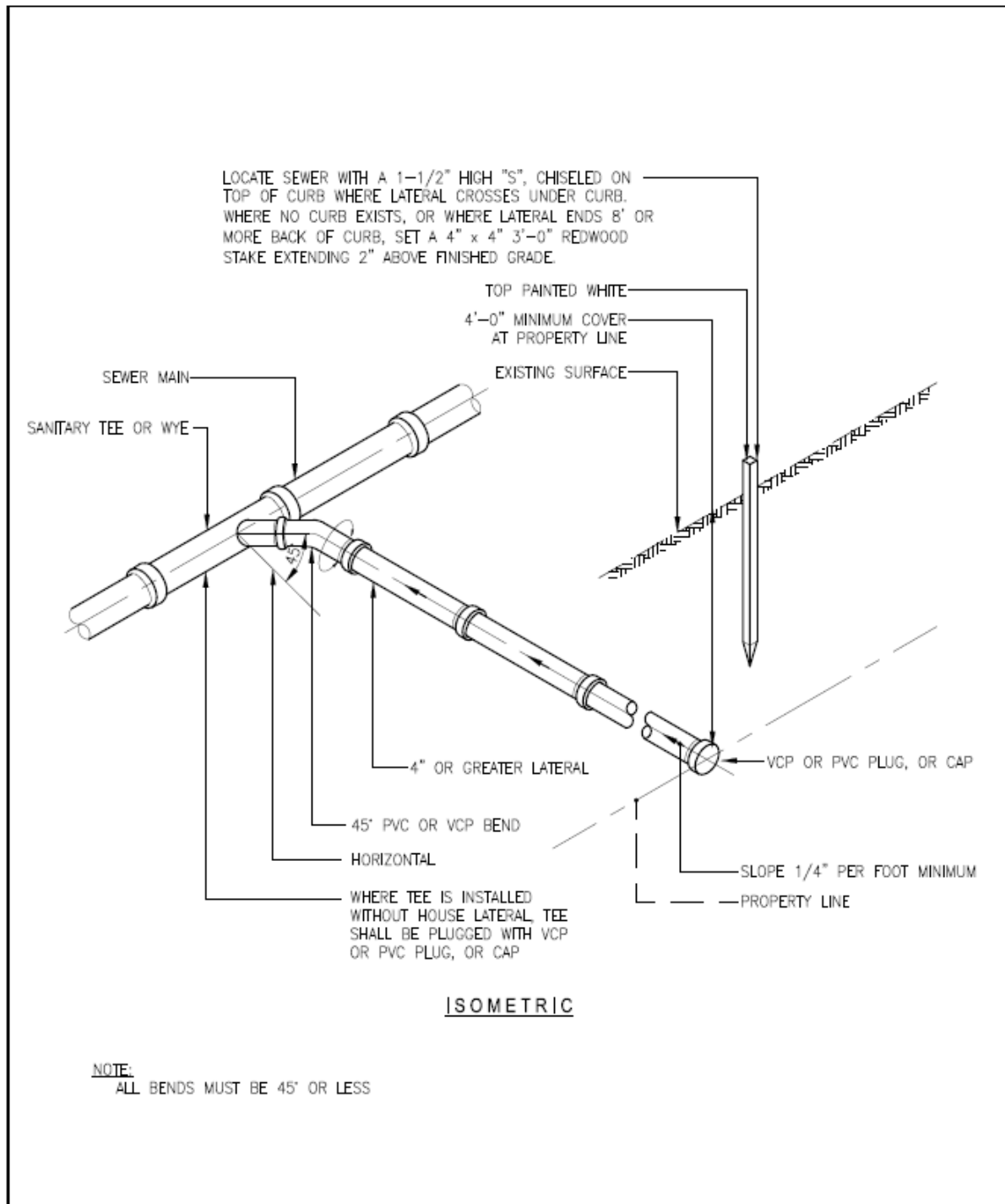
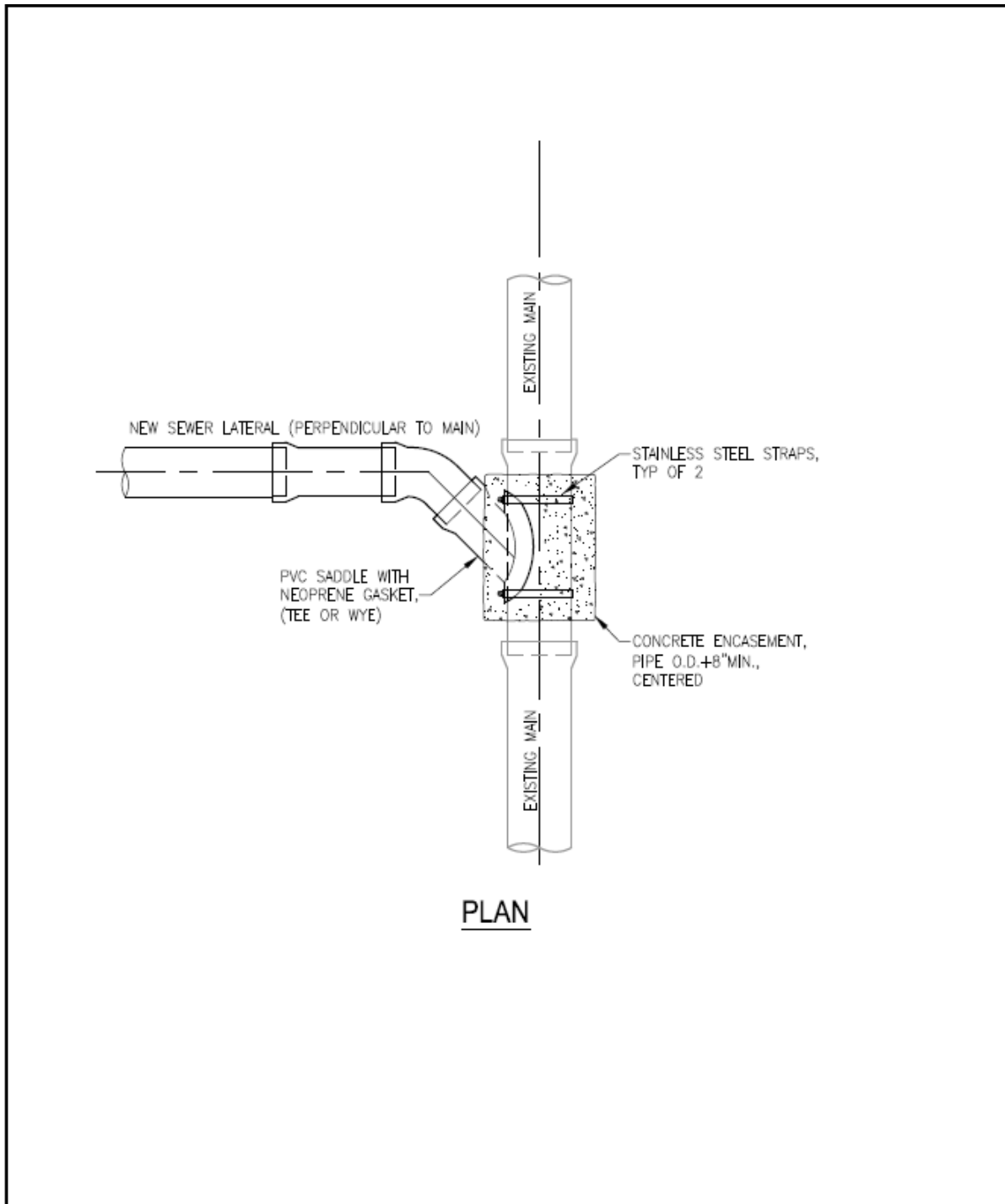

Plate 3- Typical Sewer Lateral (S-3)



		NORTH OF RIVER SANITARY DISTRICT No. 1	
		TYPICAL SEWER LATERAL	
3/26	REVISED	AECOM	DATE DRAWN 10/04
2/10	REVISED		
DATE	REVISION		SHEET NO. S-3

Plate 4- Lateral Connection to Existing Main (S-4)



PLAN

		NORTH OF RIVER SANITARY DISTRICT No. 1		
6/19	REVISED	LATERAL CONNECTION TO EXISTING MAIN		
11/13	REVISED			
2/10	REVISED			
DATE	REVISION	AECOM	DATE DRAWN 10/04	SHEET NO. S-4

Plate 5- Typical House Connection (S-5)

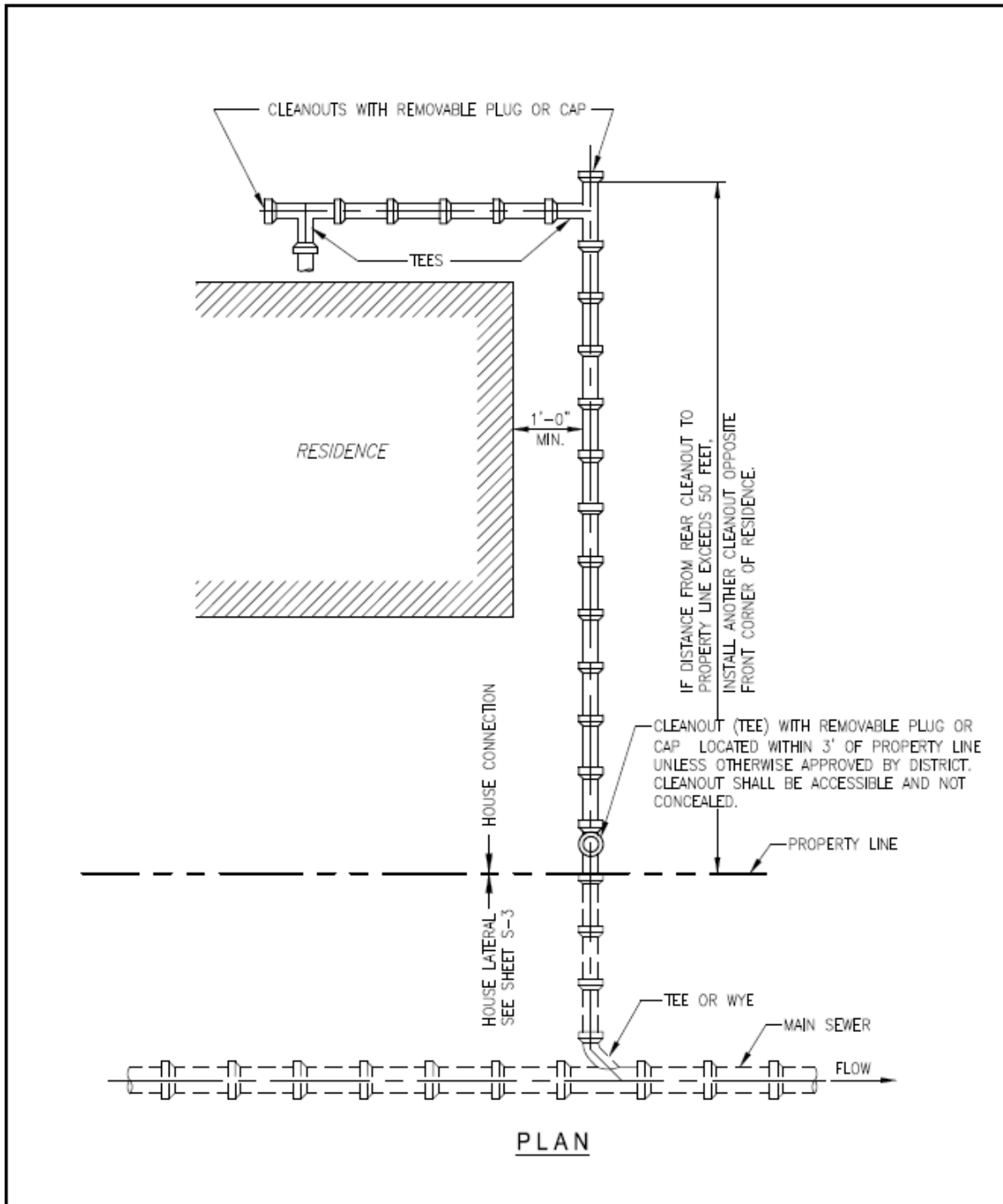

		NORTH OF RIVER SANITARY DISTRICT No. 1	
		TYPICAL HOUSE CONNECTION	
3/26	REVISED	AECOM	DATE DRAWN
2/10	REVISED		10/04
DATE	REVISION		SHEET NO. S-5

Plate 6- Inline Cleanout (S-6)

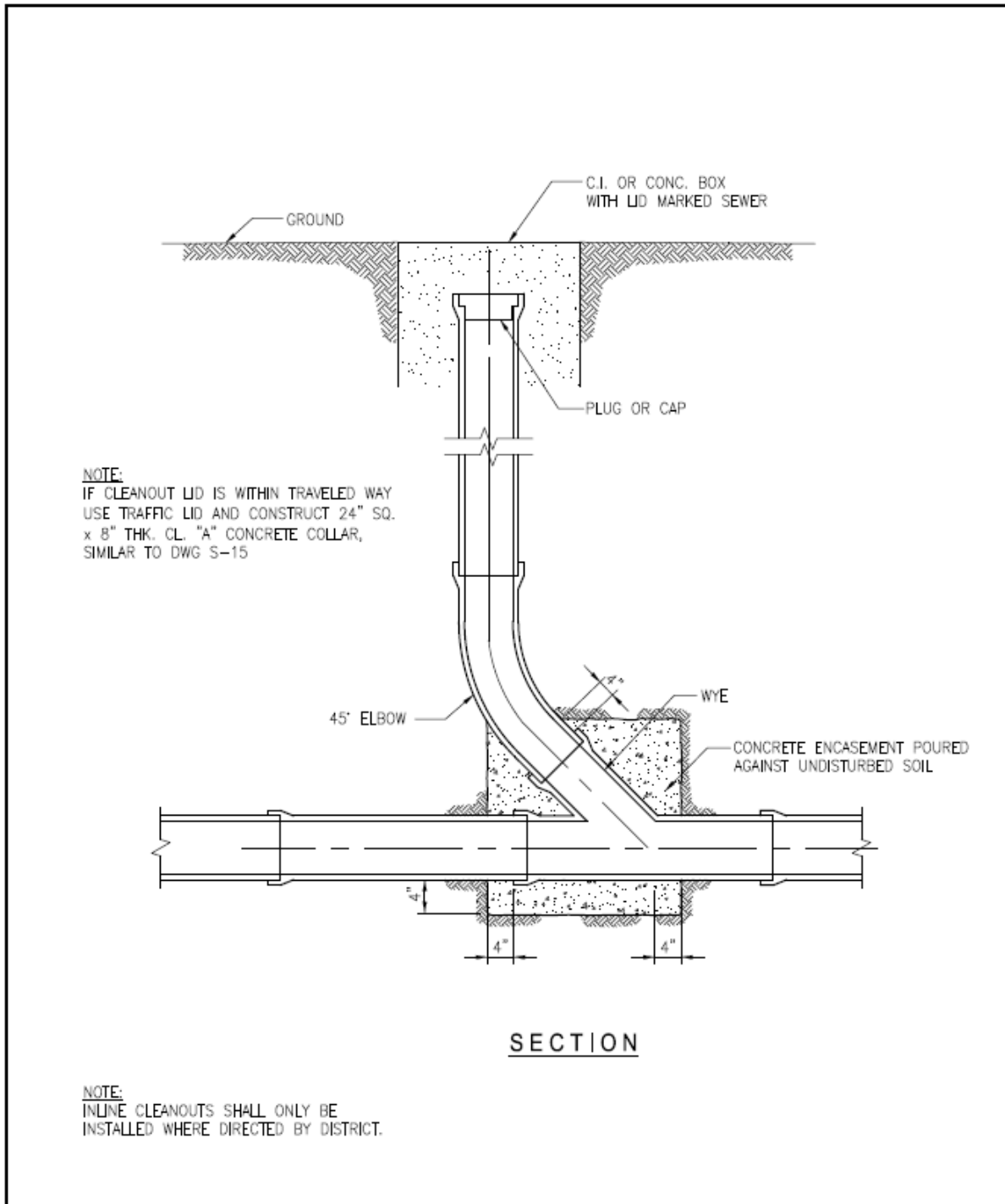

		NORTH OF RIVER SANITARY DISTRICT No. 1		
		INLINE CLEANOUT		
3/26	REVISED	AECOM		
2/10	REVISED			
DATE	REVISION	DATE DRAWN	10/04	SHEET NO. S-6

Plate 7- 48" and 60" I.D. Standard Manhole (S-7)

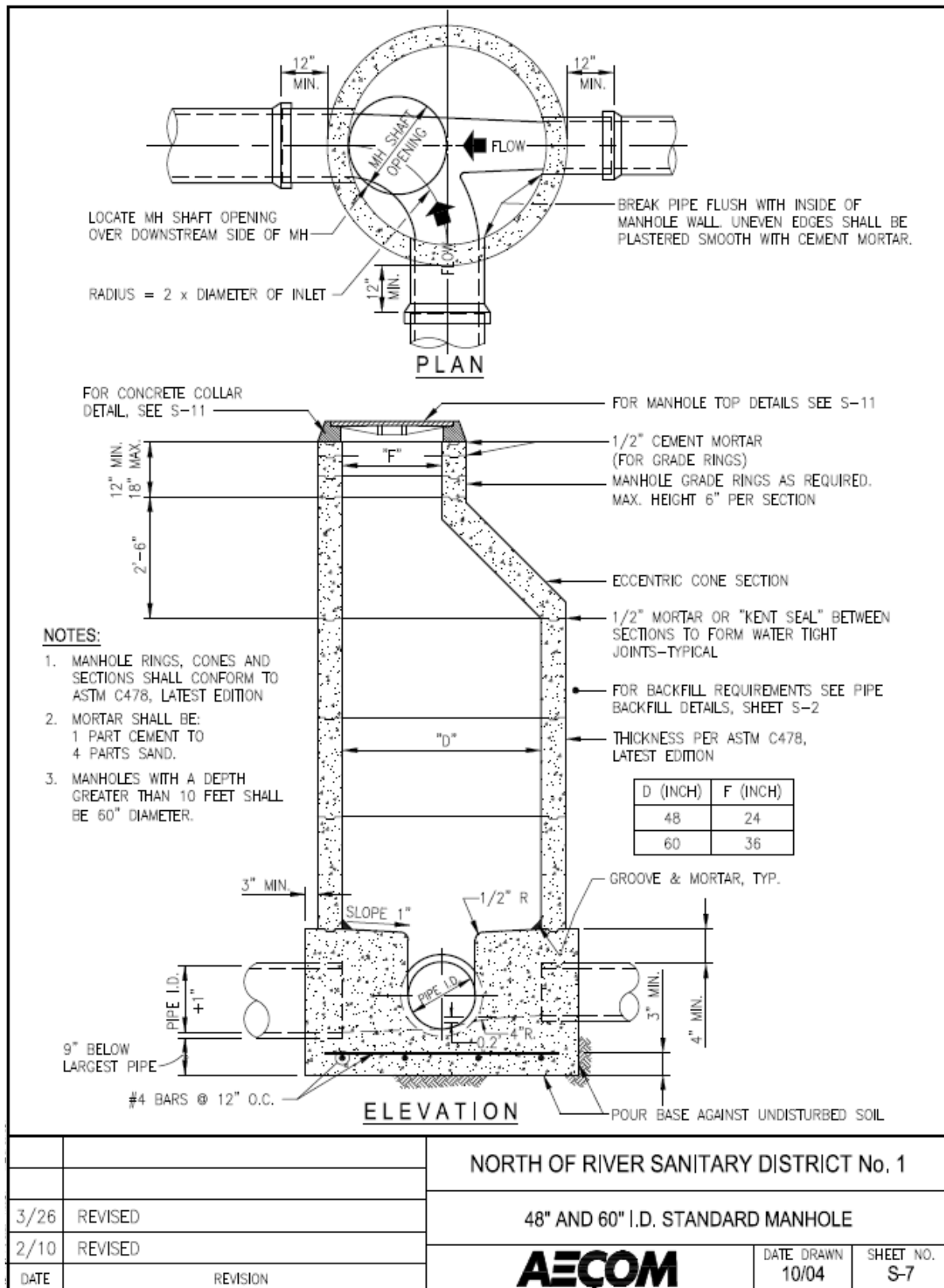
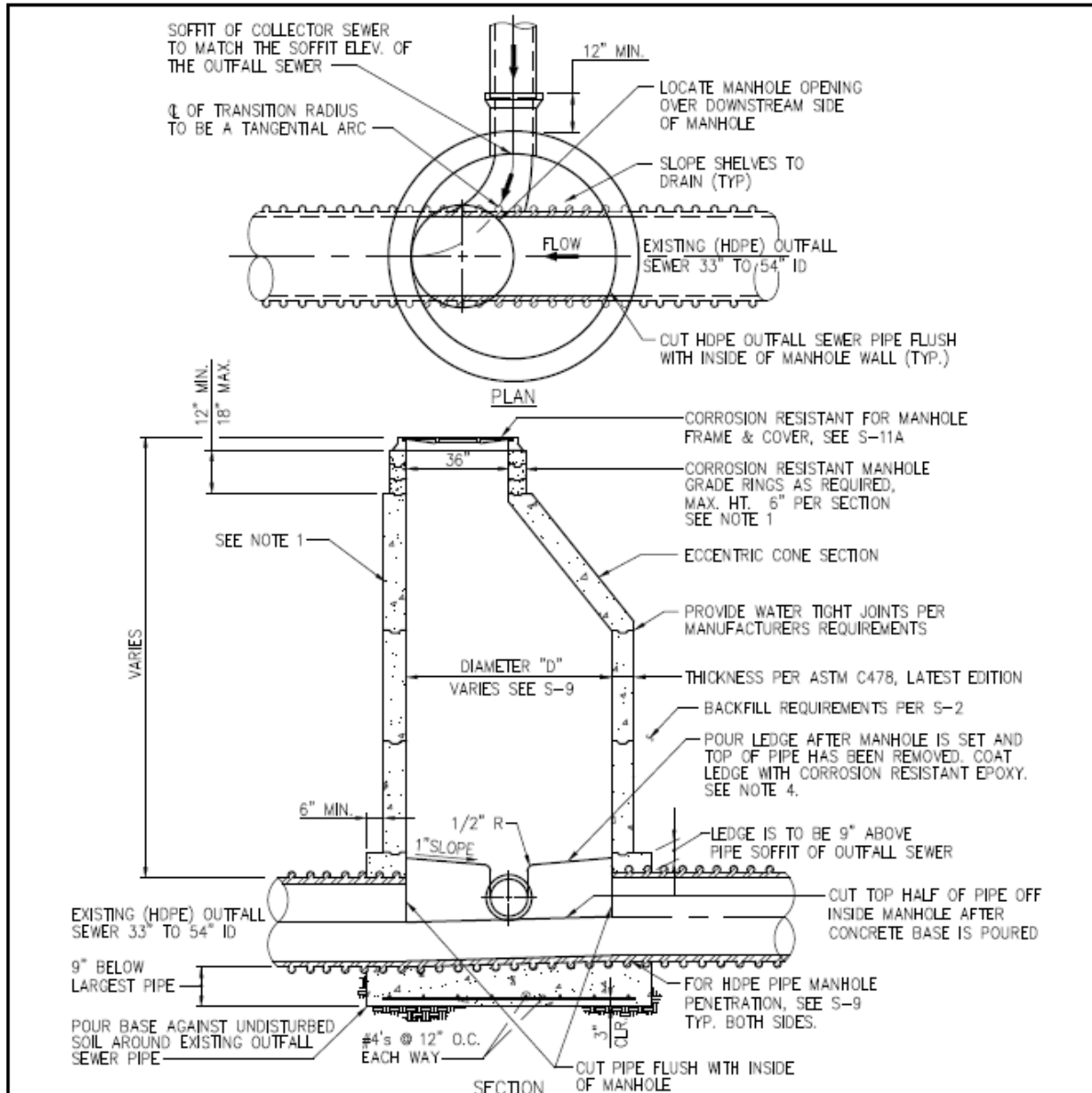

Plate 8- Standard Corrosion Resistant Manhole Connection to Existing Outfall Sewer (S-8)



- NOTES:**
1. CORROSION RESISTANT MANHOLE RINGS, CONES AND SECTIONS SHALL BE MANUFACTURED BY ARMOROCK, LLC, OR EQUAL CONFORMING TO ASTM C478.
 2. NO STEPS IN OUTFALL SEWER MANHOLES.
 3. CONTACT DISTRICT PRIOR TO CONSTRUCTION OF MANHOLE TO SCHEDULE NORSD INSPECTION AND TO COORDINATE TIE IN PROCEDURE.
 4. APPLY SOLVENT-FREE 100% SOLIDS EPOXY (RAVEN 405FS, QUADEX STRUCTURE GUARD RS, OR NEOPOXY 5300) RATED FOR GREATER THAN 1,200 PPM H₂S, MINIMUM DRY THICKNESS 3/4 - 1 INCH, TACK FREE IN 3.5 HOURS, FULLY CURED BY MANUFACTURER PRIOR TO SUBMERSION.

3/26	REVISED	NORTH OF RIVER SANITARY DISTRICT No. 1 STANDARD CORROSION RESISTANT MANHOLE CONNECTION TO EXISTING OUTFALL SEWER		DATE DRAWN	SHEET NO.
11/21	REVISED			10/04	S-8
11/13	REVISED				
2/10	REVISED				
DATE	REVISION				

Plate 9- HDPE Outfall Manhole Connection Details (S-9)

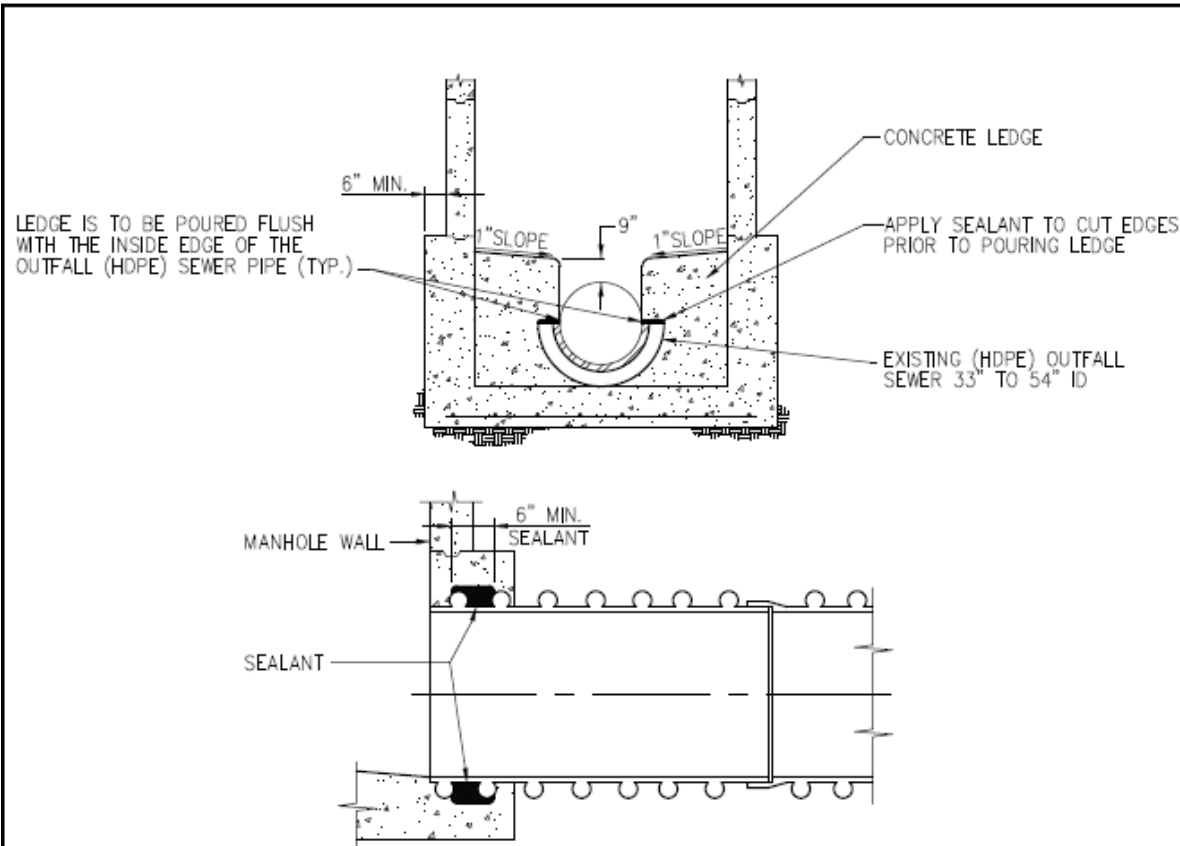

SEALANT NOTES:

1. APPLY MASTIC MANUFACTURER'S RECOMMENDED PRIMER TO THE CENTER 6" OF THE CONNECTION AREA TO BE CAST IN CONCRETE.
2. WRAP RAM-NEK, KENT SEAL, BUTYL-TITE OR EQUIVALENT MASTIC AROUND PIPE, OVER THE PRIMER, LEAVING PROTECTIVE PAPER ON UNTIL READY TO POUR CONCRETE.
3. WRAP ONE TIME PERPENDICULAR TO PIPE AXIS, THEN ONCE AGAIN DIAGONALLY (IN BETWEEN RIBS).
4. FORM CONCRETE BENCH AFTER PIPE IS INSTALLED.
5. CONCRETE SHOULD BE THOROUGHLY VIBRATED TO ENSURE NO VOIDS AROUND APPLICATION OF MASTIC.

LARGEST DIAMETER PIPE ENTERING MANHOLE	"D"
33-INCHES	60-INCHES
36-INCHES	72-INCHES
42-INCHES	72-INCHES
48-INCHES	84-INCHES
54-INCHES	84-INCHES

		NORTH OF RIVER SANITARY DISTRICT No. 1	
6/19	REVISED	HDPE OUTFALL MANHOLE CONNECTION DETAILS	
11/13	REVISED	AECOM	
2/10	REVISED	DATE DRAWN	SHEET NO.
DATE	REVISION	10/04	S-9

Plate 10- Existing HDPE Outfall Sewer and Manhole Connection Detail (S-10)

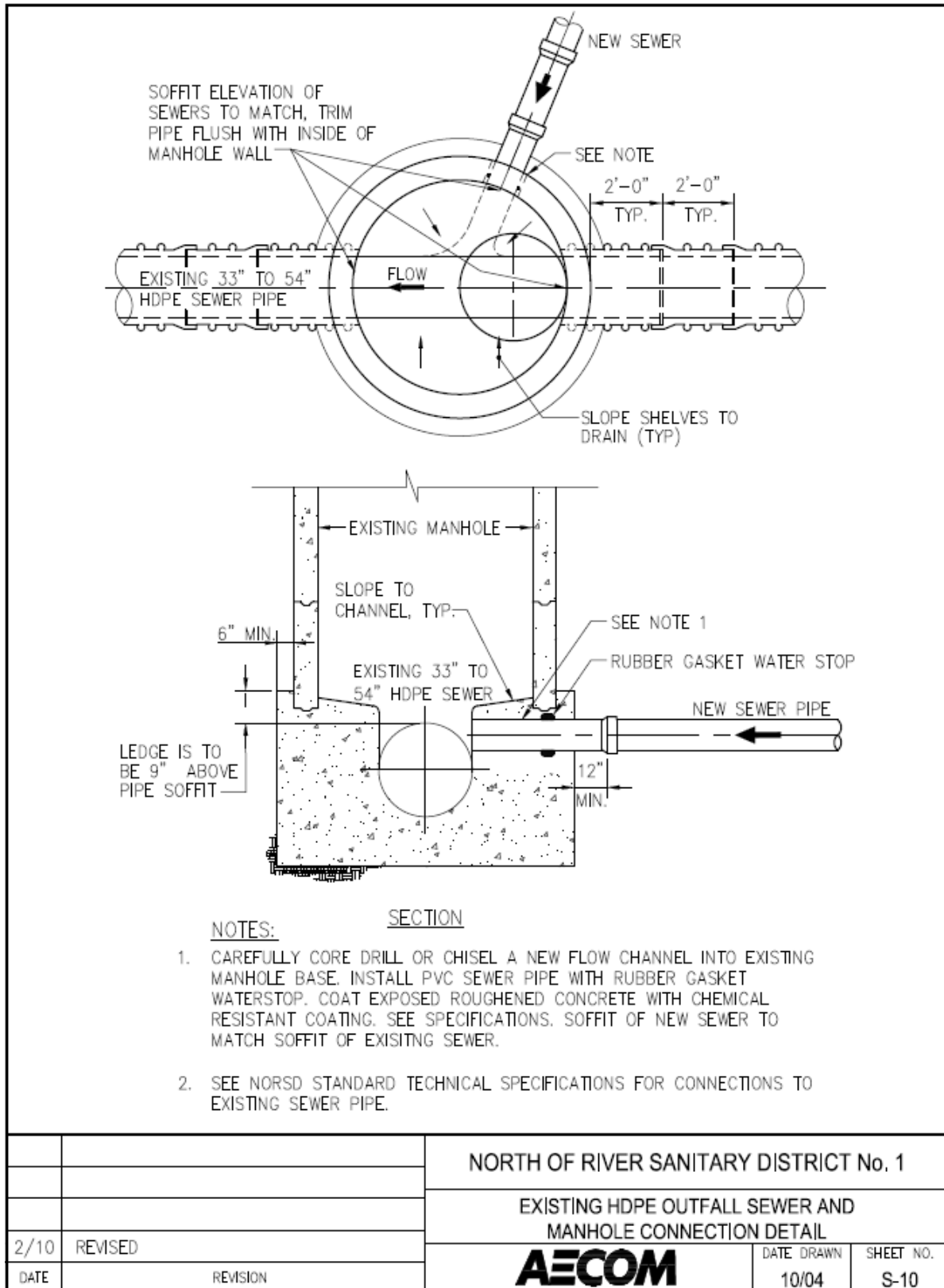
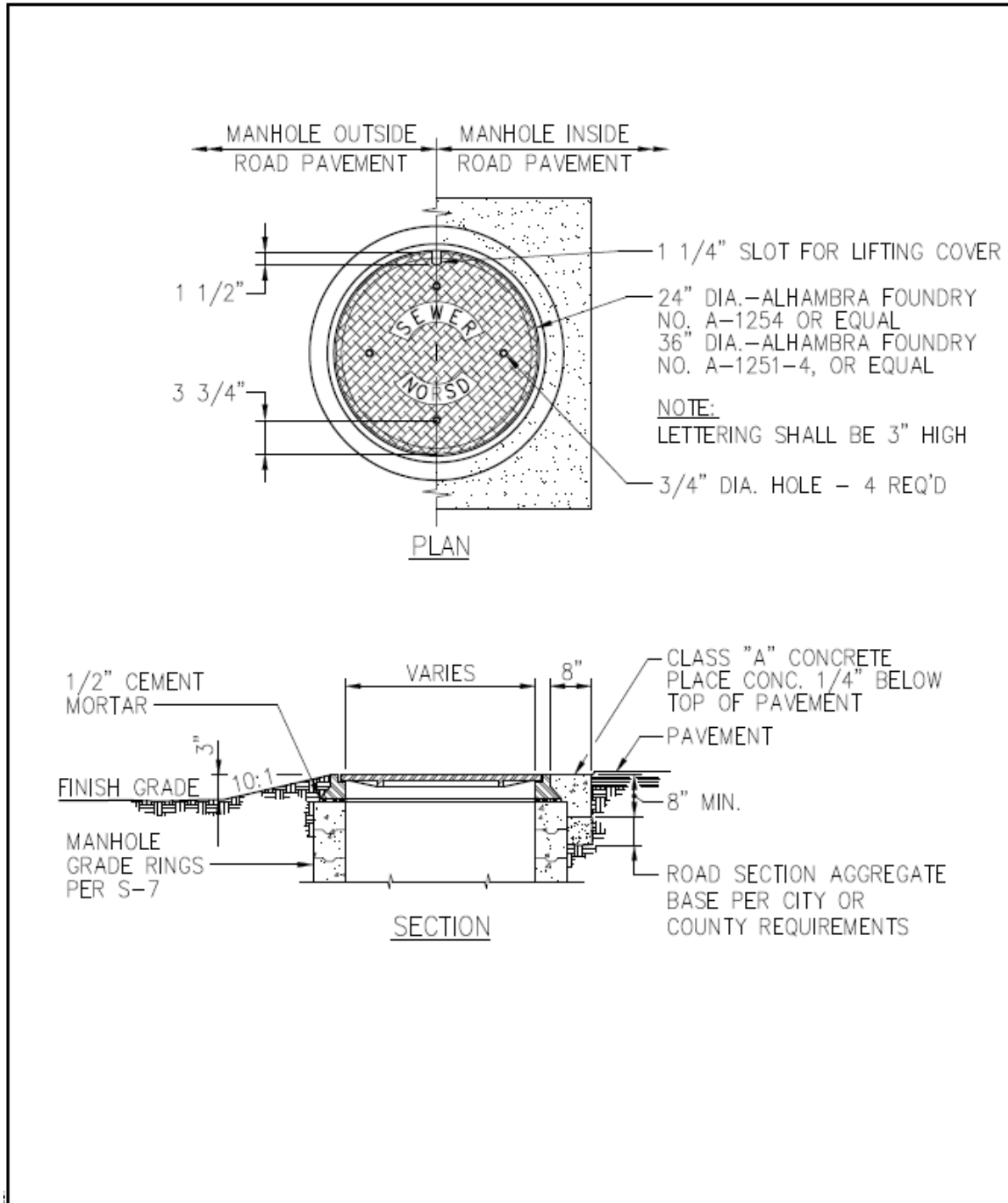
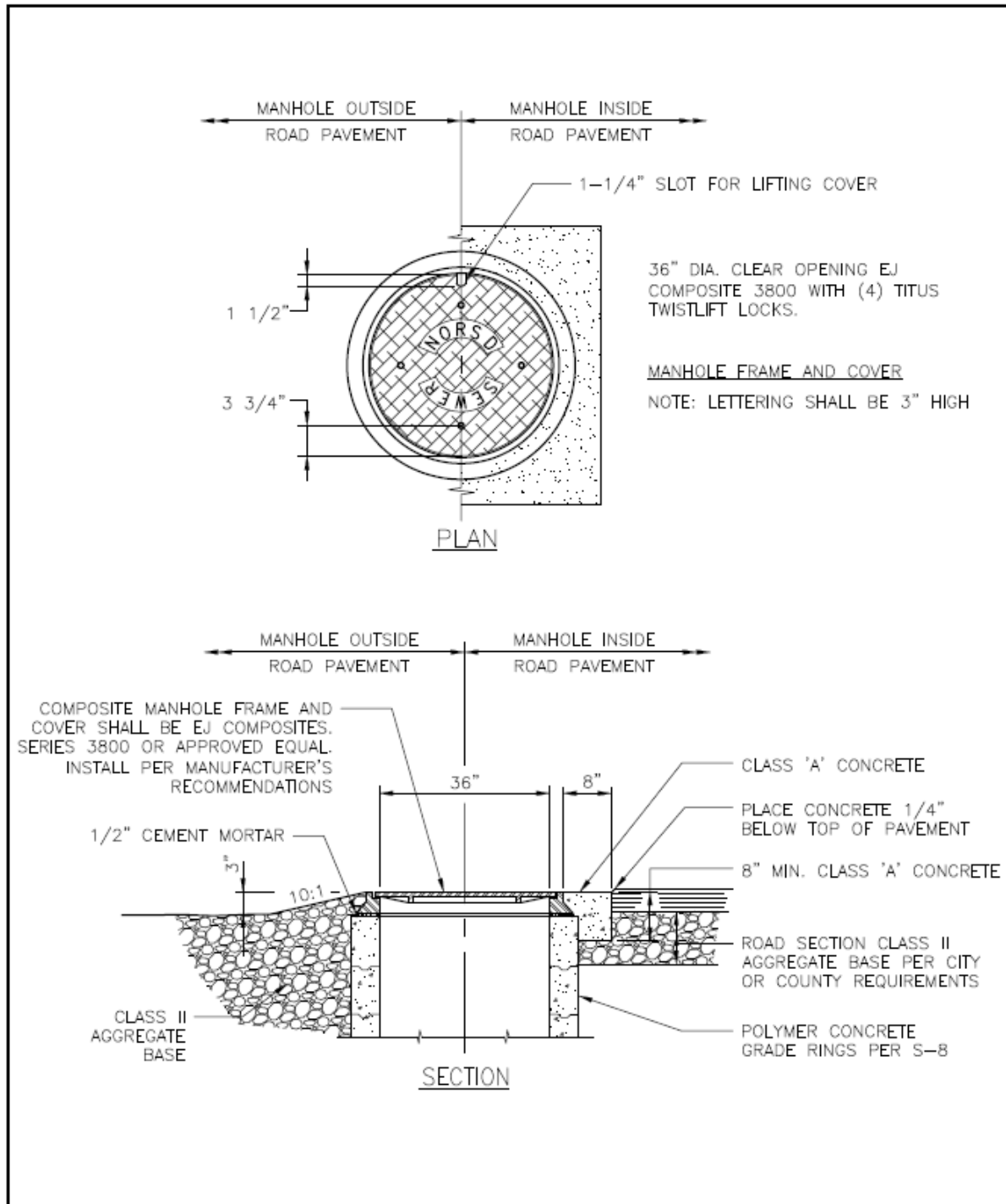

Plate 11- Manhole Frame and Cover (S-11)



3/26	REVISED	NORTH OF RIVER SANITARY DISTRICT No. 1	MANHOLE FRAME AND COVER	AECOM	DATE DRAWN 10/04	SHEET NO. S-11
11/21	REVISED					
6/19	REVISED					
2/10	REVISED					
DATE	REVISION					

Plate 12- Corrosion Resistant Manhole Frame and Cover (S-11A)



		NORTH OF RIVER SANITARY DISTRICT No. 1	
		CORROSION RESISTANT MANHOLE FRAME AND COVER	
		AECOM	DATE DRAWN 3/26
DATE	REVISION		SHEET NO. S-11A

Plate 13- Manhole- Drop Inlet (S-12)

NOTES:

1. USE DROP TYPE CONNECTION WHERE DEFFERENCE IN ELEV. BETWEEN THE MAIN AND INTERSECTING PIPE > 2.5 ft.
2. EXTEND DROP ENCASEMENT TO SPRING LINE OF INCOMING PIPE.
3. DROP TO BE SAME SIZE AS INCOMING PIPE.

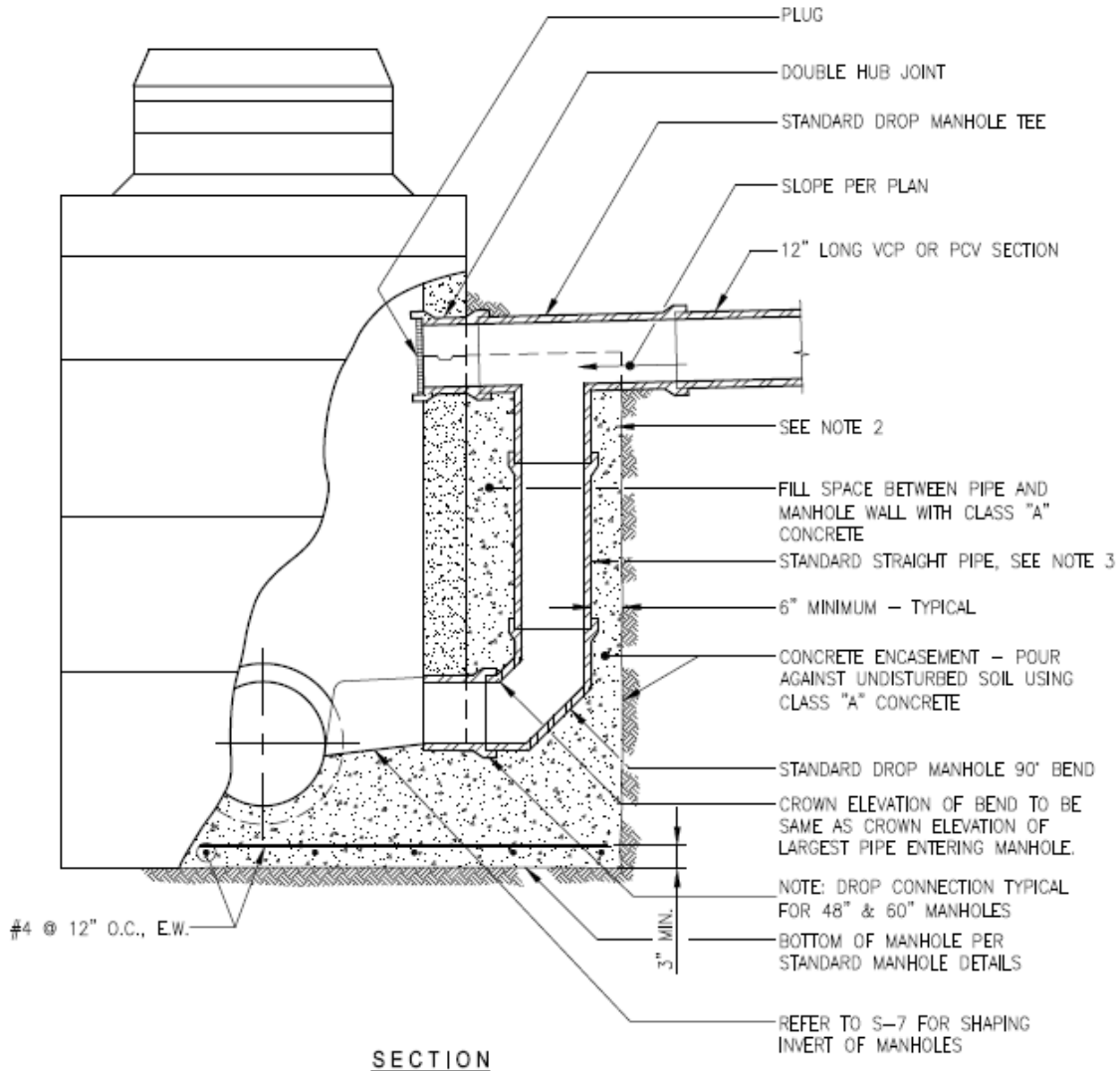

		NORTH OF RIVER SANITARY DISTRICT No. 1	
		MANHOLE - DROP INLET	
2/10	REVISED	AECOM	DATE DRAWN
DATE	REVISION		10/04
			SHEET NO. S-12

Plate 14- Steel Casing Conductor Pipe (S-13)

NOTES:

1. CASING SHALL BE INSTALLED BY THE BORE, JACK AND/OR TUNNEL METHOD.
2. SOLID POLYETHYLENE SKIDS SHALL BE PER DETAIL AND SIZED TO ALLOW INSTALLATION OF CARRIER PIPE AND PROHIBIT PIPE JOINTS FROM EXCEEDING THE PIPE MFG'S. RECOMMENDED JOINT DEFLECTION.
3. ANNULAR SPACE BETWEEN PIPE AND CASING WALL TO BE FILLED WITH SAND PER SPECIFICATIONS.
4. EACH END OF A CASING SHALL BE FITTED WITH AN END SEAL, INSTALLED AS SHOWN AND SECURELY FASTENED WITH S.S. CLAMPS. THE END SEAL SHALL BE A MIN. 1/8" THICK NEOPRENE.

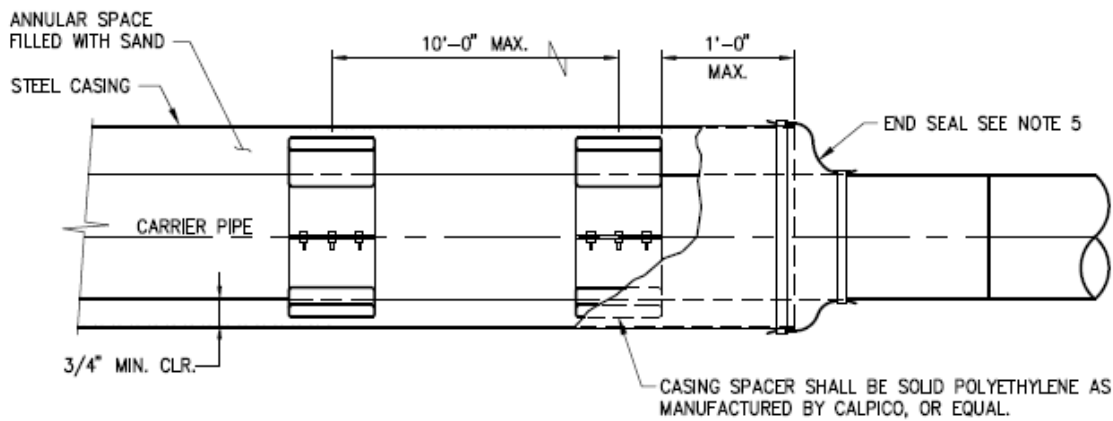
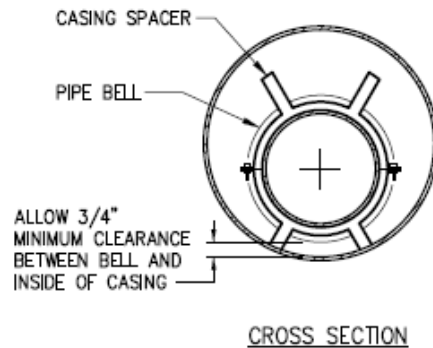

SCHEDULE - STEEL CASING FOR PIPE	
NOMINAL PIPE DIAMETER	MINIMUM CASING DIAMETER
4"	12" I.D.
6"	12" I.D.
8"	18" I.D.
10"	20" I.D.
12"	24" I.D.
16"	30" I.D.
24"	40" I.D.

		NORTH OF RIVER SANITARY DISTRICT No. 1	
		STEEL CASING CONDUCTOR PIPE	
2/10	REVISED	AECOM	DATE DRAWN
DATE	REVISION		10/04
			SHEET NO. S-13

Plate 15- Trailer Sewage Disposal Station (S-14)

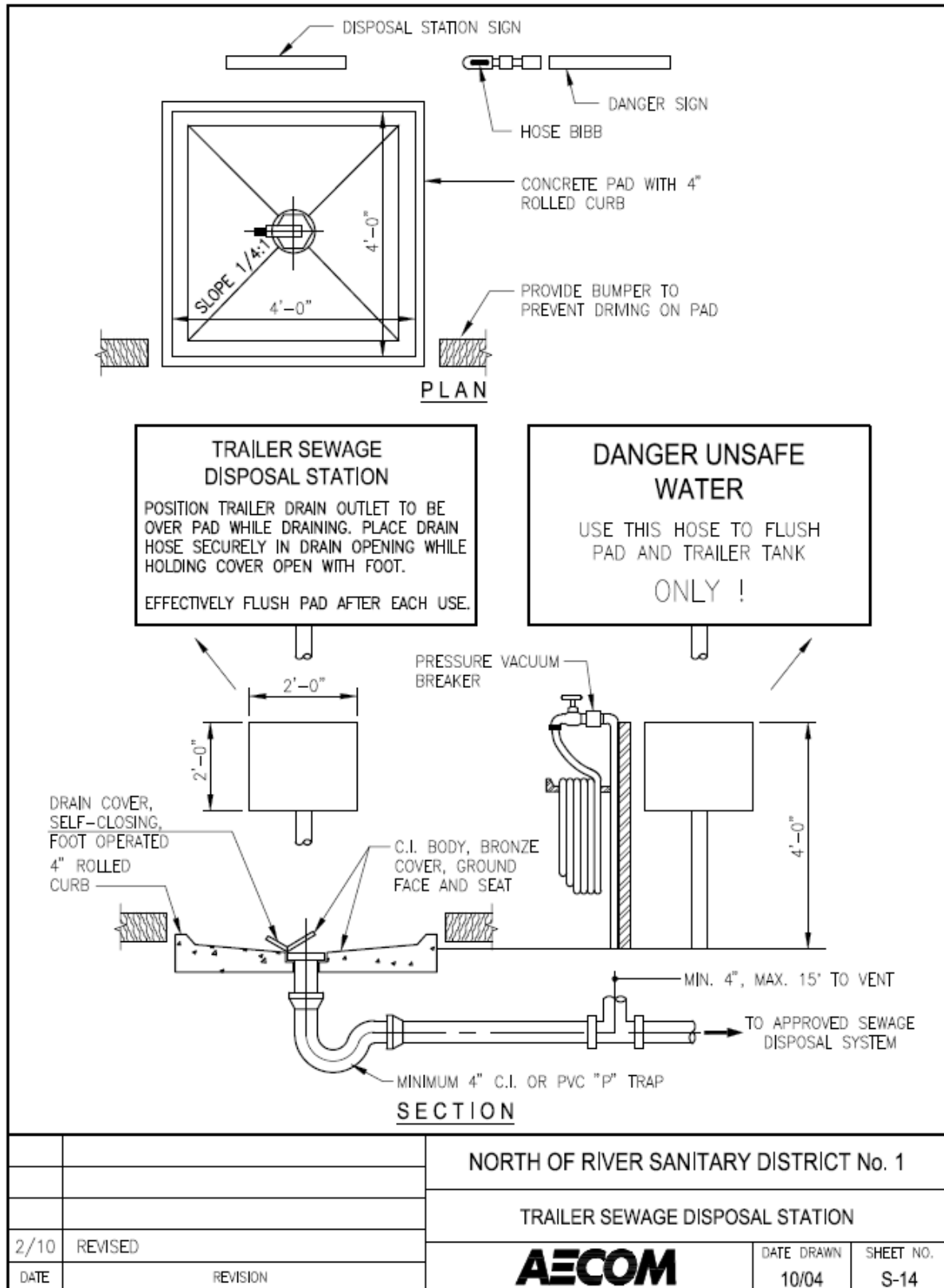
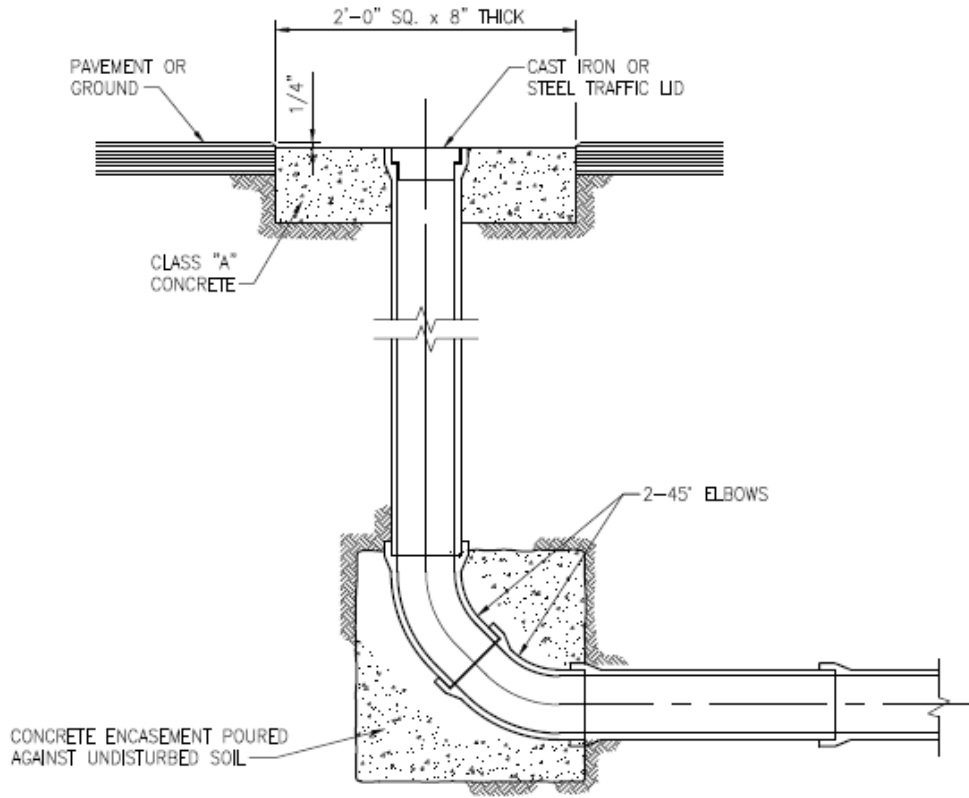

Plate 16- End of Line Cleanout (S-15)



SECTION

NOTES:

TO BE INSTALLED ONLY WHERE
 AUTHORIZED OR DIRECTED BY
 DISTRICT

		NORTH OF RIVER SANITARY DISTRICT No. 1	
		END OF LINE CLEANOUT	
6/19	REVISED	AECOM	DATE DRAWN 10/04
DATE	REVISION		

Plate 17- Typical Lift Station Piping Schematic (S-16)

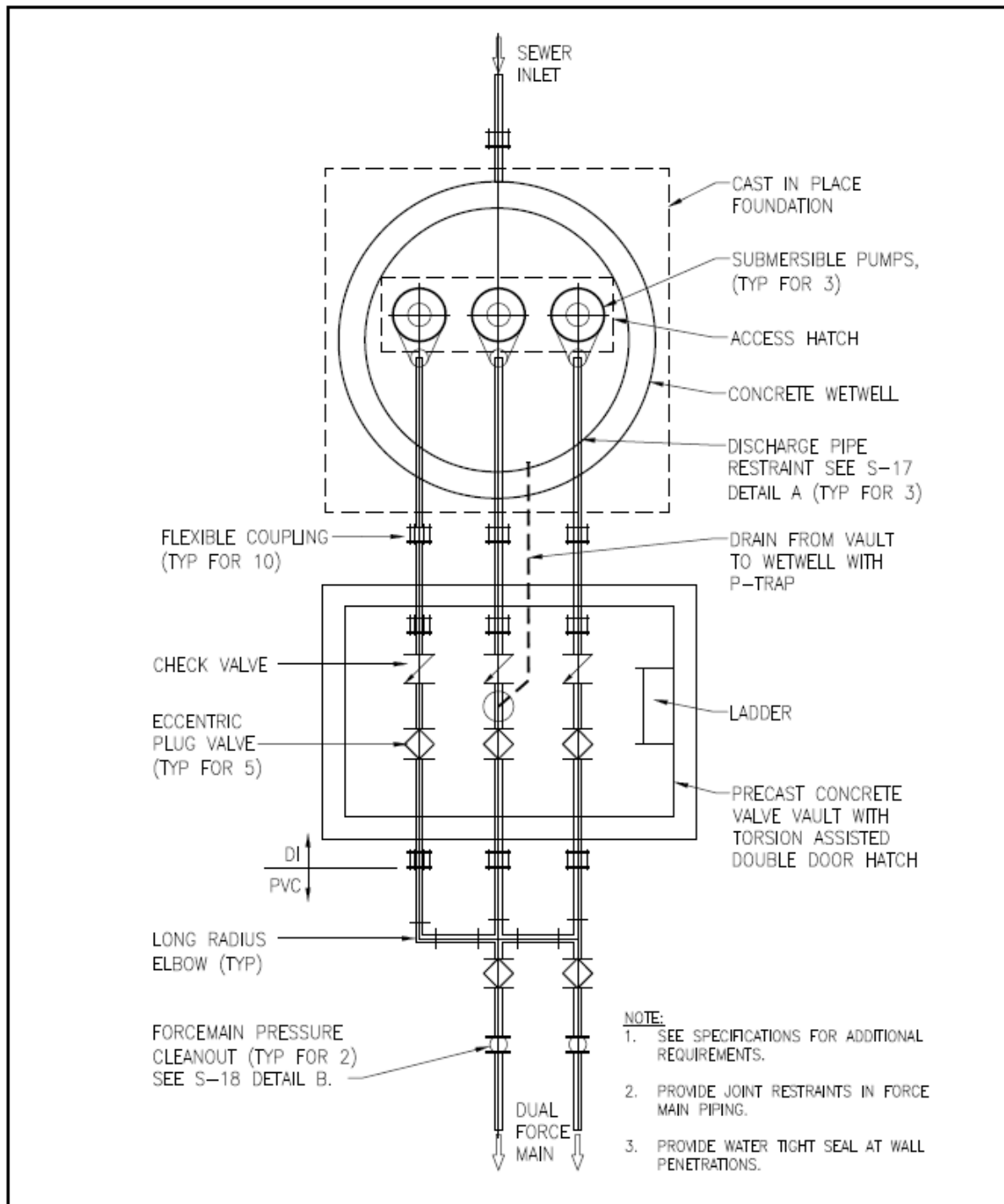

		NORTH OF RIVER SANITARY DISTRICT No. 1	
		TYPICAL LIFT STATION PIPING SCHEMATIC	
		AECOM	DATE DRAWN 3/26
DATE	REVISION		SHEET NO. S-16

Plate 18- Wet Well Pipe Restraint and Inline Pressure Clean-Out (S-17)

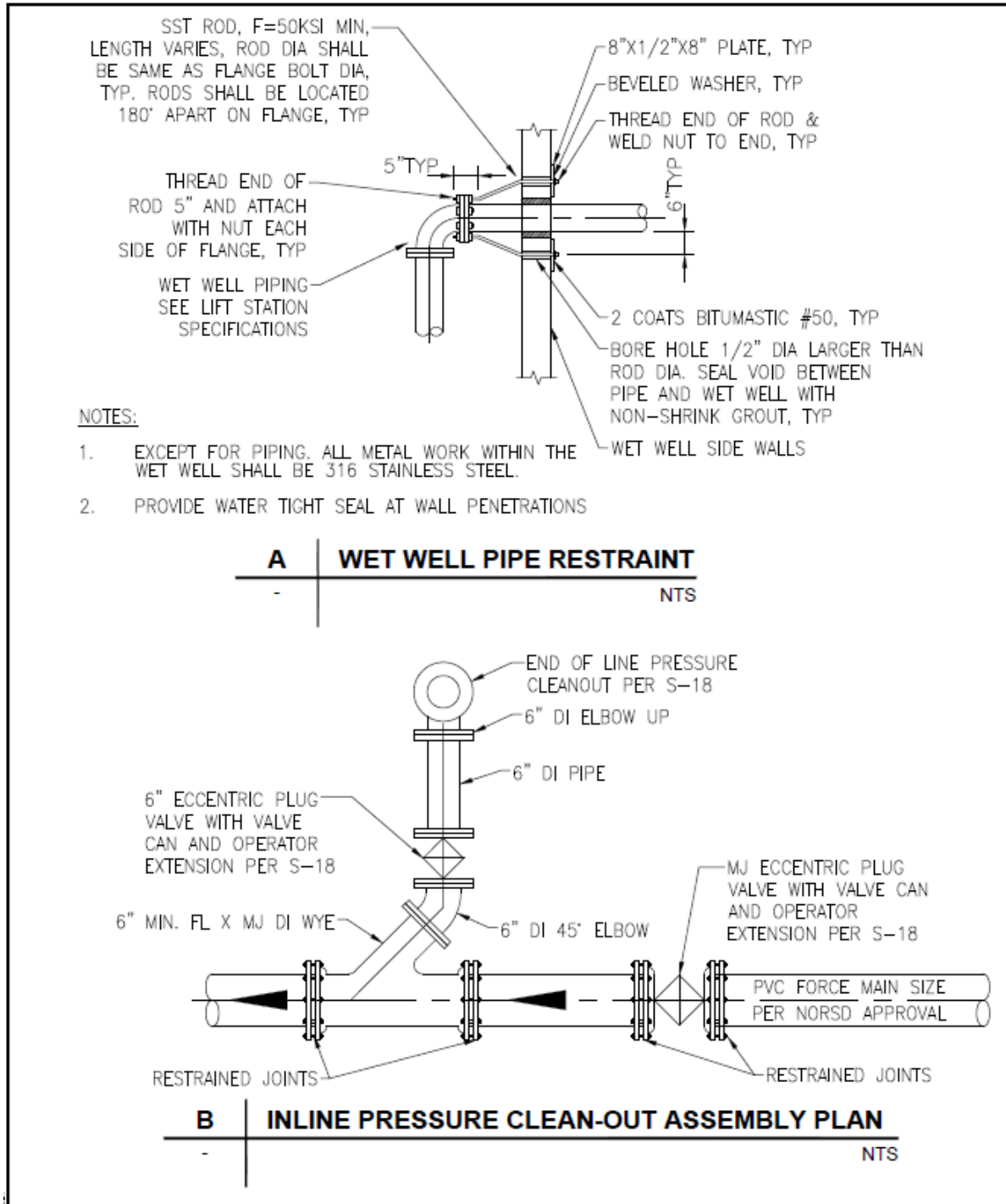

		NORTH OF RIVER SANITARY DISTRICT No. 1	
		WET WELL PIPE RESTRAINT AND INLINE PRESSURE CLEAN-OUT	
		AECOM	
DATE	REVISION	DATE DRAWN 3/26	SHEET NO. S-17

Plate 19- Pressure Clean-Out Details (S-18)

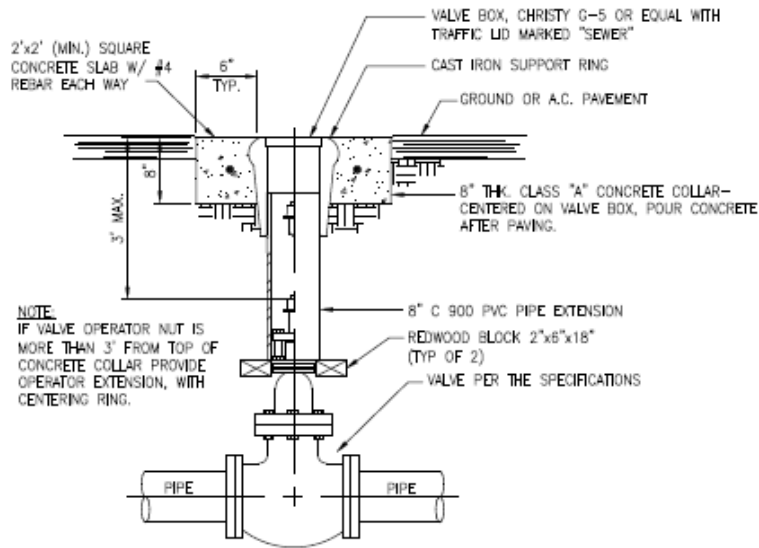

A VALVE BOX DETAIL

NTS

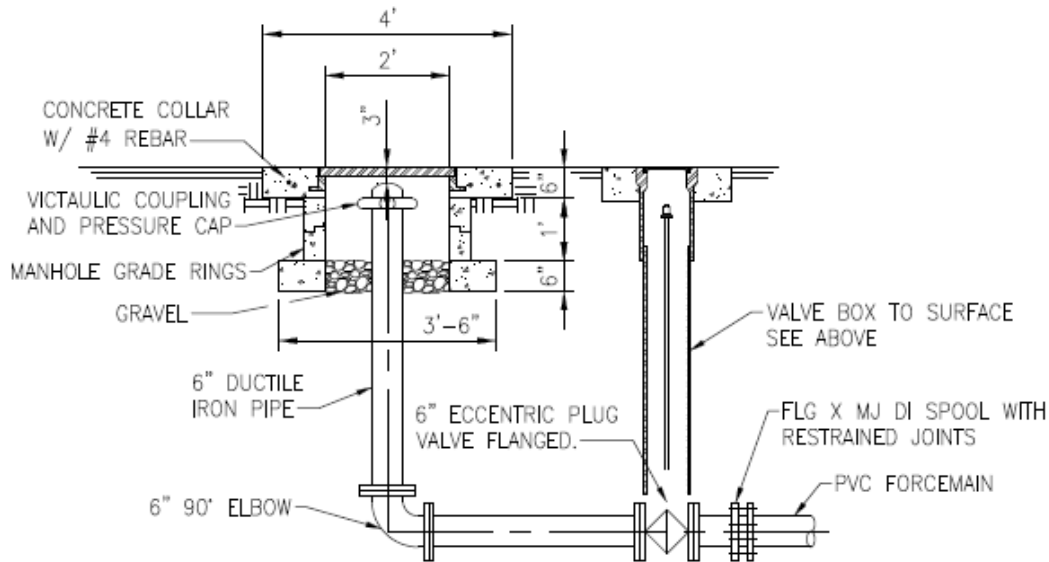

B END OF LINE PRESSURE CLEAN-OUT ASSEMBLY PLAN

NTS

		NORTH OF RIVER SANITARY DISTRICT No. 1	
		PRESSURE CLEAN-OUT DETAILS	
		AECOM	
DATE	REVISION	DATE DRAWN 3/26	SHEET NO. S-18

Plate 20- Grease Interceptor (S-19)

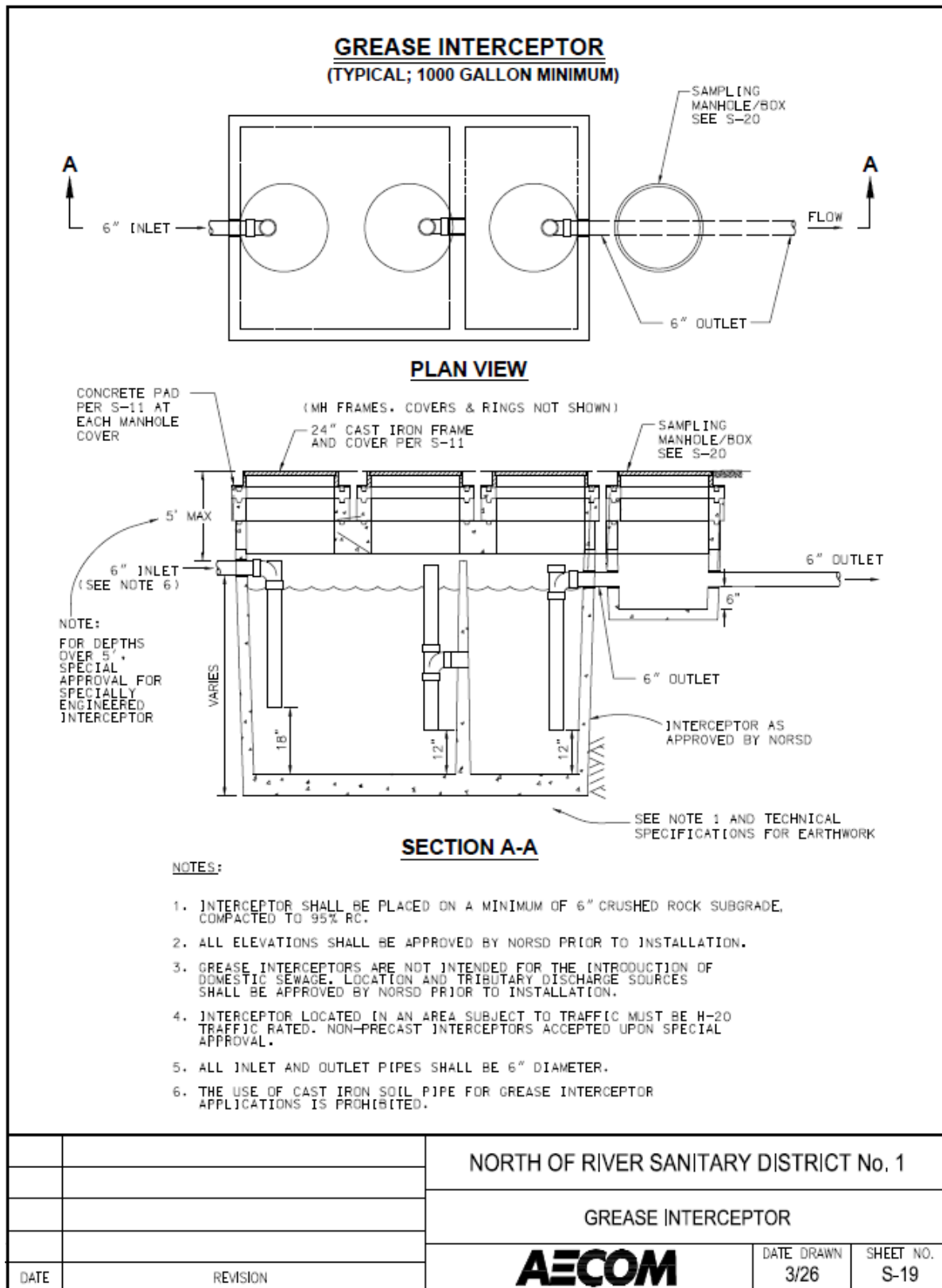
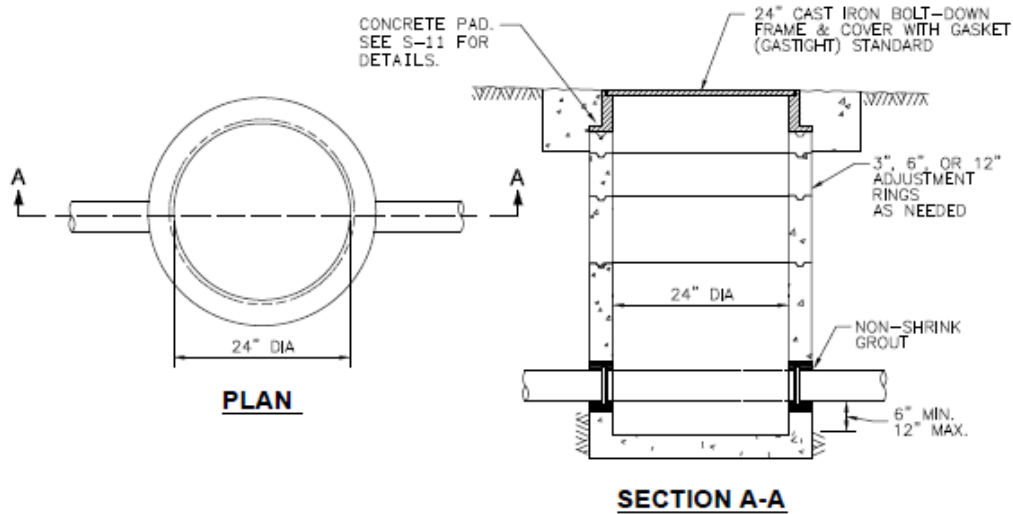

Plate 21- Precast Sampling Structures (S-20)

PRECAST SAMPLING STRUCTURES

SAMPLING MANHOLE

(OUTSIDE)



		NORTH OF RIVER SANITARY DISTRICT No. 1	
		PRECAST SAMPLING STRUCTURES	
		AECOM	DATE DRAWN
DATE	REVISION		3/26
			SHEET NO.
			S-20

Plate 22- Sand-Oil Interceptor (S-21)

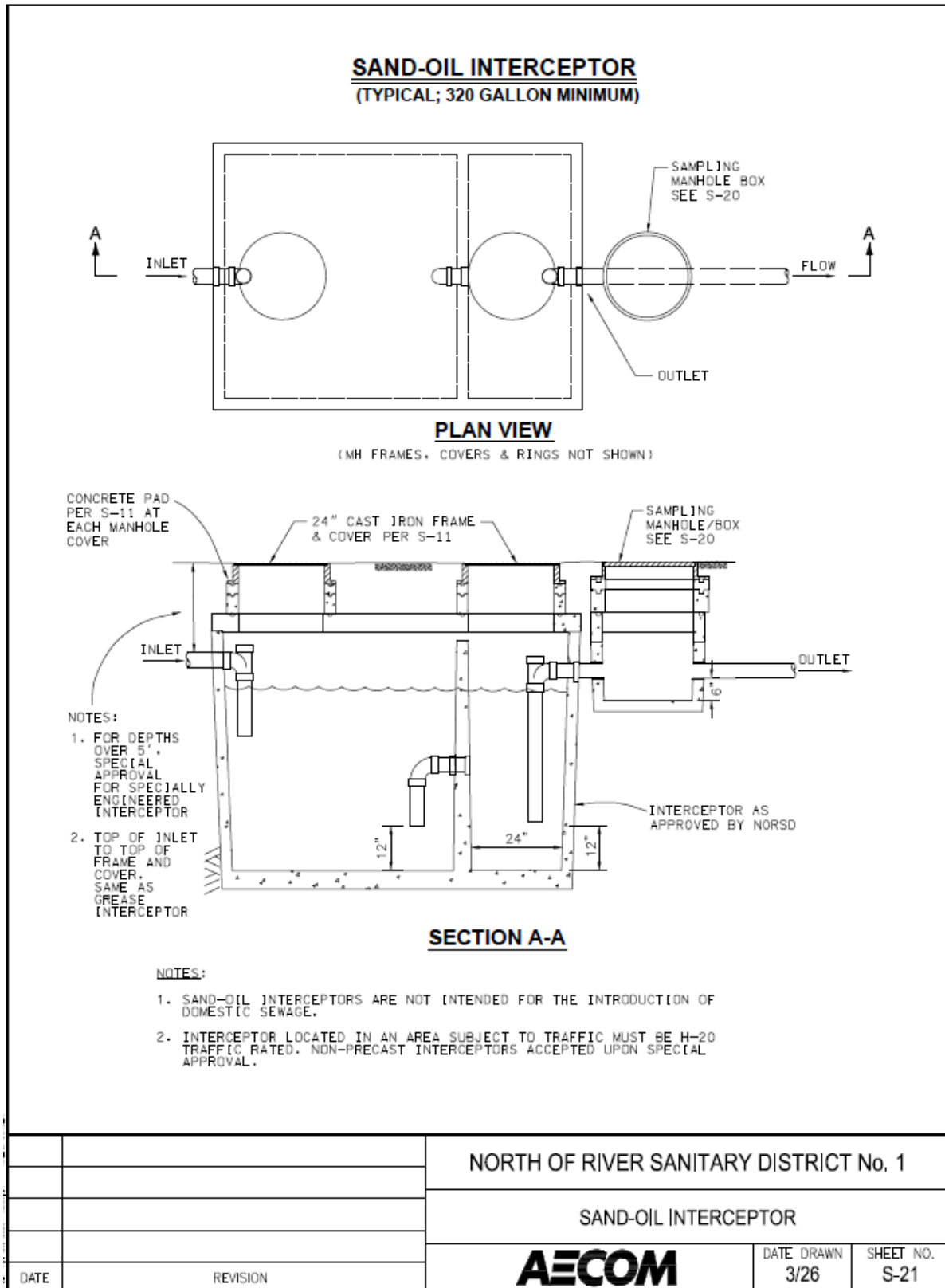

Part 4- APPENDICES

Appendix A- FORMS

Appendix A.1 Sanitary Sewer System Improvements Contract

CONTRACT NO. 20__ - __ SANITARY SEWER SYSTEM IMPROVEMENTS

This SANITARY SEWER SYSTEM IMPROVEMENTS CONTRACT (the “**Contract**”) dated _____, 20__ is made by and between North of River Sanitary District No. 1 (the “**District**”) and _____, a California limited liability company (the “**Owner**”).

RECITALS

A. The District provides sewer and wastewater treatment services to those parcels within its Service Area, as depicted in **Exhibit A**, attached hereto and incorporated herein.

B. Owner desires to design and construct certain Sewer System Improvements, as more particularly described herein, and connect those improvements to the District’s existing sewer system, subject to the terms and conditions set forth herein.

C. Upon Owner’s completion of the construction of the Sewer System Improvements, Owner desires to dedicate to the District and the District desires to accept from Owner the Sewer System Improvements for inclusion into the District’s existing sanitary sewer system, subject to the terms and conditions set forth herein.

NOW, THEREFORE, in consideration of the foregoing terms and conditions, and for other good and valuable consideration, the receipt and adequacy of which is hereby acknowledged, the District and Owner agree as follows:

AGREEMENT

ARTICLE I

SANITARY SEWER SYSTEM IMPROVEMENTS TO BE CONSTRUCTED

1. Construction of the Sewer System Improvements. Owner shall design and construct those Sewer System Improvements **included in Tract** ____, as more particularly described in **Exhibit B**, attached hereto and incorporated herein, on those certain parcels listed in **Exhibit C**, attached hereto and incorporated herein (the “**Parcels**”).

2. District Specifications. The Owner shall design and construct the Sewer System Improvements in accordance with the District’s “Standard Specifications for Sanitary Sewer System Improvements” (“**District Specifications**”), attached hereto and incorporated herein as **Exhibit D**. Owner shall be responsible for verifying elevations and locations of existing sanitary sewers and shall be responsible for providing Sewer System Improvements to the point of connection(s) to the District’s existing sanitary sewer system.

3. Owner's Engineer. The Owner hereby names as its engineer to prepare the Plans and Specifications for the proposed Sewer System Improvements:

NAME
ADDRESS
CITY, ST ZIPCODE
XXX-XXX-XXXX

ENGINEER, LIC#

4. Ownership of the Sewer System Improvements. Upon (a) Owner's completion of the construction of the Sewer System Improvements, and (b) approval by the District, ownership of the Sewer System Improvements shall pass from Owner to the District. Owner shall reasonably cooperate with the District to document and record the conveyance of such improvements.

ARTICLE II FEES

Owner shall pay each of the following fees to the District:

1. A *plan check fee* in the amount of \$_____ prior to start of construction of the main line sewer(s). This fee is inclusive of Phases Phases 1 and 2 of the Tract.

2. An *inspection fee* in the amount of \$_____ (\$1.25 x _____ linear feet) prior to start of construction of the main line sewer(s). This fee is inclusive of Phases 1 and 2 of the Tract.

3. A *capacity fee* in the amount of \$_____ per single family residential equivalent (subject to change) upon issuance of a lateral permit and prior to connection.

4. A *permit fee* in the amount of \$___ upon issuance of a lateral permit prior to each lateral hookup.

5. A *line charge fee* in the amount of \$__ upon issuance of a lateral permit prior to each lateral hookup.

**ARTICLE III
INSURANCE REQUIREMENTS**

Owner shall carry and, upon execution of this Contract, submit to the District those forms of insurance identified below. Owner shall not perform any construction activities associated with the Sewer System Improvements unless and until Owner has filed proof of insurance with and received approval from the District.

2. Worker’s Compensation and Liability Insurance.
3. Liability insurance, which includes bodily injury coverage, for an amount not less than \$2,000,000 per person and \$4,000,000 per occurrence.
4. Property damage insurance for an amount not less than \$1,000,000.

**ARTICLE IV
BOND REQUIREMENTS**

Upon execution of this Contract, Owner shall submit those bonds identified below. If authorized, as indicated below, Owner may submit a guarantee bond in lieu of a performance and payment bond. Owner shall not perform any construction activities associated with the Sewer System Improvements unless and until the bonds identified below have been submitted to and reviewed and approved by the District.

Performance Bond:	Required	<input type="checkbox"/>
	Not required	<input checked="" type="checkbox"/>
Payment Bond:	Required	<input type="checkbox"/>
	Not required	<input checked="" type="checkbox"/>
Guarantee Bond:	Required	<input type="checkbox"/>
	Not required	<input checked="" type="checkbox"/>

**ARTICLE VII
PROCEDURE**

In designing and constructing the Sewer System Improvements, Owner shall comply with and adhere to the procedure set forth below:

1. Plans and Specifications.

Owner shall submit three copies of its proposed Plans and Specifications for the Sewer System Improvements to the District for review. Upon such review, the District shall provide Owner with the District’s comments and/or corrections to Owner’s proposed Plans and Specifications.

After addressing the District's comments and/or corrections, Owner shall submit three copies of its proposed Final Plans and Specifications to the District for review and approval. In addition, Owner shall submit any and all grants of easements required for the construction and maintenance of the Sewer System Improvements to the District for review and approval.

Within approximately 20 business days after Owner's submission of its proposed Final Plans and Specifications and Grants of Easements, if any, the District shall review the submitted documents and notify Owner of any additional changes or corrections that may be required. If no further changes or corrections are required, the Final Plans and Specifications and Grants of Easements shall be presented to the District's Board of Directors ("**Board**") at its next regularly scheduled meeting for approval.

2. Record Drawings and AutoCAD File. After the Board approves the Final Plans and Specifications and Grants of Easements, Owner shall submit record drawings to the District for review and approval. Upon approval, Owner shall submit an electronic copy of the approved record drawings in an AutoCAD format to the District. Owner shall survey all Improvements as built and provide the District with the survey data in electronic form for incorporation in the District's GIS system. AutoCAD format shall include the following:

- The coordinate system used for the CAD drawing must be per the values derived from the Control Points indicated in **Exhibit E**, attached hereto.
- Owner shall perform a record drawing survey of the sewer collection system features such as manholes, cleanouts, and associated structures. Manholes and cleanouts shall be surveyed at the center of cover, and surveyed invert elevations are to be provided for manholes. Structures shall be surveyed at the perimeter corners of facility.
- Record drawing survey deliverables, including the Survey Control Worksheet, attached hereto as **Exhibit F**, shall be stamped by a California licensed surveyor or Civil Engineer (pre 1982).
- Layer names shall be spelled out fully (e.g., "Sewer Line" instead of "SL;" "Manhole" instead of MH).
- Features must reside on the correct layer.
- Attributes must be clearly present in the drawing through Object Data in AutoCAD Map.
- Lines and points must snap together.
- Lines must snap to the center of the manhole /cleanout and not to the edge of the manhole symbol.
- Lines must not be broken except at manholes, cleanouts or lift stations. If there are bends in the line between manholes, they must be represented as polylines with vertices at the bends.

- Control points shall be per Exhibit E.

3. Final Acceptance of the Work by the District. After completion of construction of the Sewer System Improvements, the District shall review the Sewer System Improvements and, in its sole discretion, the Board may issue a Notice of Final Acceptance. Owner shall not connect any residential, commercial, industrial, or other development to the Sewer System Improvements unless and until the District issues the Notice of Final Acceptance. The District will require the immediate disconnection of any and all connections made prior to the District's issuance of the Notice of Final Acceptance.

ARTICLE IX MISCELLANEOUS

1. Guarantee. Owner shall guarantee all materials, equipment, and workmanship of the Sewer System Improvements for a period of one year after the date of Final Acceptance. If Owner does not comply with this one-year guarantee, the District may correct or otherwise address the defect at the expense of Owner.

2. Indemnity. Owner shall indemnify and hold the District harmless from and against all Claims, actually or allegedly, directly or indirectly, arising out of or related to Owner's obligations set forth in this Contract.

3. Termination. Owner may terminate this Contract at any time prior to commencing construction of the Sewer System Improvements upon written notice to the District in which event, the District shall prepare a statement summarizing the costs to the District and deposits made by Owner. If the cost(s) exceed the deposit(s), Owner shall pay the difference to the District within 30 calendar days. If the deposit(s) exceed the cost(s), the District shall reimburse the difference to Owner within 30 calendar days.

4. Notice. Any notice to be given hereunder by either party to the other party shall be by personal delivery in writing or by registered or certified mail, postage prepaid, return receipt requested. Either party may change its address by written notice in accordance with this paragraph. The addresses of the parties to this agreement as of the date of this agreement are as follows:

DISTRICT:

North of River Sanitary District No. 1
204 Universe Avenue
Bakersfield, California 93308

OWNER:

NAME
ADDRESS
CITY, STATE ZIPCODE

5. Entire Agreement. This Contract contains all the terms of the agreement between the District and Owner concerning the Sanitary Sewer System Improvements to be constructed and paid for by Owner and dedicated to and accepted by the District for inclusion into the District's sanitary sewer system.

6. Counterparts. This Contract may be executed in any number of counterparts, each of which shall be considered as an original and be effective as such.

IN WITNESS WHEREOF, the District and the Owner have executed this Employment Agreement, as of the date and year first above written.

DISTRICT:

North of River Sanitary District No. 1:

Patrick Ostly, District Manager

OWNERS:

Name
a California limited liability company

Name, Title

Name, Title

Appendix A.2 Grant of Easement

Recording Requested By
And For the Benefit of:
North of River Sanitary District No. 1

When Recorded, Mail to:

North of River Sanitary District No. 1
204 Universe Avenue
Bakersfield, CA 93308

GRANT OF EASEMENT

FOR A VALUABLE CONSIDERATION, receipt of which is hereby acknowledged

hereinafter called "GRANTOR", hereby grants to

NORTH OF RIVER SANITARY DISTRICT NO. 1
a political subdivision of the State of California

hereinafter called "GRANTEE",

An easement and right-of-way to lay, construct, reconstruct, maintain, operate, repair, renew, change the size of and remove water pipelines with appurtenant fittings, structures and other equipment, with the right of ingress to and egress from the same, over, through, Section _____, Township _____, Range _____ M.D.B. & M., in the County of KERN, State of California, and as shown on Exhibit "A" attached hereto and described by the following parcels:

GRANTORS and its successors further grant to the GRANTEE the right to trim such trees and other foliage and to cut such roots on said property as may be necessary for the construction, protection, maintenance, operation, renewal and replacement of such pipe line or lines necessary to carry sewage over, under, across and through said land, and the full exercise of the rights hereby granted, and covenants that no building or permanent improvement will be placed thereon.

"LEGAL DESCRIPTION"

IN WITNESS WHEREOF, Grantor has executed this Grant of Easement this _____ day of _____, 20____.

Grantor:

Witness
Official Seal

Appendix A.3 Certificate of Acceptance

CERTIFICATE OF ACCEPTANCE

THIS IS TO CERTIFY that the interest in the real property conveyed by Right-of-Way Deed dated the _____ day of _____, 20_____, from _____ to NORTH OF RIVER SANITARY DISTRICT NO. 1, a political subdivision of the State of California, is hereby accepted by order of the Board of Directors on _____, 20_____, and the Grantee consents to the recordation thereof by its duly authorized officer.

President of the Board of Directors
North of River Sanitary District No. 1

ATTEST:

Secretary
North of River Sanitary District No. 1

(Seal)

Appendix A.4 Performance Bond

PERFORMANCE BOND

We, _____, as Principal(s), and _____, as Surety, jointly and severally, bind ourselves, our heirs, representatives, successors and assigns, as set forth herein, to the

NORTH OF RIVER SANITARY DISTRICT NO. 1
(Herein called District) for payment of the penal sum of _____

_____ Dollars (\$ _____),
lawful money of the United States. The District's contract is for the construction of

SANITARY SEWER SYSTEM IMPROVEMENTS
DESCRIBED IN CONTRACT NO. _____,
DATED _____, 20____,
BETWEEN THE OWNER AND THE DISTRICT

THE CONDITION OF THIS OBLIGATION IS SUCH that if the Principal shall in all things abide by and will truly keep and perform the covenants, and agreements in the contract, and any alteration thereof made as therein provided, on his part to be kept and performed at the time and in the manner therein specified, and shall indemnify and save harmless the District, the District's Engineer, and their consultants, and each of their directors, officers, employees and agents, as therein stipulated, this obligation shall become null and void, otherwise, it shall be and remain in full force and effect.

Surety agrees that no change, extension of time, alteration, or addition to the terms of the Contract, or the work to be performed thereunder, or the plans and specifications shall in any wise affect its obligation on this bond, and it does hereby waive notice thereof.

Furthermore, this obligation shall remain in full force and effect for a period of one year commencing on the date of Final Acceptance by the District of the improvements described in the Contract between the Principal and the District.

Principal and Surety agree that if the District is required to engage the services of an attorney in connection with the enforcement of this bond, each shall pay District's reasonable attorney's fees incurred, with or without suit, in addition to the above sum.

Executed in four original counterparts on _____, 20____.

Principal(s)

(Seal if Corporation)

By _____

Title _____

(Attach Acknowledgment of Authorized Representative of Principal)

Any claims under this bond may be addressed to:

_____ (name and address of Surety)

_____ (name and address of Surety's
agent for service of process in
California, if different from
above)

_____ (telephone number of Surety's agent
in California)

(Attach Acknowledgment)

(Attorney-in-Fact)

Approved:

(Attorney for District)

Notice:

No substitution or revision to this bond form will be accepted. Sureties must be authorized to do business in and have an agent for service of process in California. Certified copy of Power of Attorney must be attached.

Appendix A.5 Payment Bond

PAYMENT BOND

We, _____, as Principals(s) and _____ as Surety, jointly and severally, bind ourselves, our heirs, representatives, successors and assigns, as set forth herein, to the

NORTH OF RIVER SANITARY DISTRICT NO. 1

(herein called District) for payment of the penal sum of _____

_____ Dollars (\$ _____), lawful money of the United States. The Owner's contract is for the construction of

SANITARY SEWER SYSTEM IMPROVEMENTS
DESCRIBED IN CONTRACT NO. _____,
DATED _____, 20_____,
BETWEEN THE OWNER AND THE DISTRICT

If Principal or any of his Contractor subcontractors fail to pay any of the persons named in Section 3181 of the California Civil Code, or amounts due under the Unemployment Insurance Code with respect to work or labor performed under the contract, or for any amounts required to be deducted, withheld, and paid over to the Franchise Tax Board from the wages of employees of the contractor and his subcontractors pursuant to Section 13020 of the Unemployment Insurance Code, with respect to such work and labor, then Surety will pay the same in an amount not exceeding the sum specified above, and also will pay, in case suit is brought upon his bond, such reasonable attorney's fees as shall be fixed by the court.

This bond shall insure to the benefit of any of the persons named in Section 3181 of the California Civil Code, so as to give a right of action to them or their assigns in any suit brought upon this bond.

Surety agrees that no change, extension of time, alteration, or addition to the terms of the Contract, or the work to be performed thereunder, or the plans and specifications shall in any wise affect its obligation on this bond, and it does hereby waive notice thereof.

Furthermore, this obligation shall remain in full force and effect for a period of one year commencing on the date of Final Acceptance by the District of the improvements described in the Contract between the Principal and the District.

Principal(s) and Surety agree that should District become a party of any action on this bond that each will also pay District's reasonable attorney's fees incurred therein in addition to the sum above set forth.

Executed in four original counterparts on _____, 20 ____.

Principal(s)

(Seal if Corporation)

By _____

Title _____

(Attach Acknowledgment of Authorized Representative of Owner)

Any claims under this bond may be addressed to:

_____ (name and address of Surety)

_____ (name and address of Surety's agent for service of process in California, if different from above)

_____ (telephone number of Surety's agent in California)

(Attach Acknowledgment)

By _____
(Attorney-in-Fact)

Approved:

(Attorney for District)

Notice:

No substitution or revision to this bond form will be accepted. Sureties must be authorized to do business in and have an agent for service of process in California. Certified copy of Power of Attorney must be attached.

Appendix A.6 Contractor's Certificate Regarding Workers' Compensation

CONTRACTOR'S CERTIFICATE
REGARDING WORKERS' COMPENSATION

Description of Contract:

SANITARY SEWER SYSTEM IMPROVEMENTS AS DESCRIBED IN CONTRACT NO. _____, DATED
_____, 20___, BETWEEN THE NORTH OF RIVER SANITARY DISTRICT NO. 1
AND _____

Labor Code Section 3700:

"Every employer except the State and all political subdivisions or institutions thereof, shall secure the payment of compensation in one or more of the following ways:

(a) By being insured against liability to pay compensation in one or more insurers duly authorized to write compensation insurance in this State.

(b) By securing from the Director of Industrial Relations a certificate of consent to self-insure, which may be given upon furnishing proof satisfactory to the Director of Industrial Relations of ability to self-insure and to pay any compensation that may become due to his employees."

I am aware of the provisions of Section 3700 of the Labor Code which require every employer to be insured against liability for worker's compensation or to undertake self-insurance in accordance with the provisions of that code, and I will comply with such provisions before commencing the performance of the work of this contract.

Dated: _____, 20___

(Contractor)

By _____

(Official Title)

(Seal)

(Labor Code Section 1861 provides that the above certificates must be signed and filed by the Contractor with the District prior to performing any work under this contract.)

Appendix A.7 Certificate of Insurance for Workers' Compensation

CERTIFICATE OF INSURANCE

Description of Contract:

SANITARY SEWER SYSTEM IMPROVEMENTS AS DESCRIBED IN CONTRACT NO. _____,
 DATED _____, 20_____, BETWEEN THE NORTH OF RIVER
 SANITARY DISTRICT NO. 1 AND _____

Type of Insurance: Workers' Compensation Insurance

THIS IS TO CERTIFY that the following policy has been issued by the below-
 stated company in conformance with the requirements of Section 8-1 and 8-2 of
 the General Provisions of the North of River Sanitary District No. 1
 Specifications for Sanitary Sewer System Improvements and is in force at this
 time.

The Company will give at least 30 days' written notice by certified mail to the
 District prior to any material change or cancellation of said policy.

POLICY NUMBER	EXPIRATION DATE	LIMITS OF LIABILITY
		Statutory Limits Under the Laws of the State of California

 Named Insured (Contractor)

 Insurance Company

 Street Number

 Street Number

 City and State

 City and State

By _____
 (Company Representative)

State of _____)

) ss. (SEE NOTICE ON PAGE 2 OF 2)

County of _____)

On this ____ day of _____, 20____, before me personally came
 _____ to me know, who being duly sworn, did depose and
 say: that _____ is an authorized representative of
 the _____ and acknowledged to me that
 _____ executed the within instrument on behalf of said
 insurance company.

In witness whereof, I have signed and affixed my official seal on the date in this certificate first above written.

NOTARY PUBLIC

Insurance Company Agent for Service
of Process in California:

Named

Agency

Street Number

Street Number

City and State

City and State

Telephone Number

Telephone Number

This certificate or verification of insurance is not an insurance policy and does not amend, extend, or alter the coverage afforded by the policies listed herein. Notwithstanding any requirement, term, or condition of any contract or other document with respect to which this certificate or verification of insurance may be issued or may pertain, the insurance afforded by the policies described herein is subject to all the terms, exclusions and conditions of such policy.

NOTICE:

No substitution or revision to the above certificate form will be accepted. If the insurance called for is provided by more than one insurance company, a separate certificate in the exact above form shall be provided for each insurance company.

Appendix A.8 Insurance Endorsement for Workers' Compensation

INSURANCE ENDORSEMENT

Description of Contract:

SANITARY SEWER SYSTEM IMPROVEMENTS AS DESCRIBED IN CONTRACT NO. _____, DATED _____, 20_____, BETWEEN THE NORTH OF RIVER SANITARY DISTRICT NO. 1 AND _____

Type of Insurance: _____ Workers' Compensation Insurance

This endorsement forms a part of Policy No. _____

ENDORSEMENT

It is agreed that with respect to such insurance as is affordable by the policy, the Company waives any right of subrogation it may acquire against the District, the District's Engineer, and their consultants, and each of their directors, officers, agents and employees by reason of any payment made on account of injury, including death resulting therefrom, sustained by any employee of the insured, arising out of the performance of the above referenced contract.

This endorsement does not increase the Company's total limits of liability.

Named Insured (Contractor)

Insurance Company

Street Number

Street Number

City and State

City and State

By _____
(Company Representative)

(SEE NOTICE ON PAGE 2 OF 2)

State of _____)
County of _____) ss.

On this ___ day of _____, 20___, before me personally came _____ to me known, who being duly sworn, did depose and say: that _____ is an authorized representative of the _____ and acknowledged to me that _____ executed the within instrument of behalf of said insurance company.

In witness whereof, I have signed and affixed my official seal on the date in this certificate first above written.

NOTARY PUBLIC

NOTICE:

No substitution or revision to the above endorsement form will be accepted. If the insurance called for is provided by more than one policy, a separate endorsement in the exact above form shall be provided for each policy.

Appendix A.9 Certificate of Insurance for Liability Insurance

CERTIFICATE OF INSURANCE

Description of Contract:

SANITARY SEWER SYSTEM IMPROVEMENTS AS DESCRIBED IN CONTRACT NO. _____, DATED _____, 20____, BETWEEN THE NORTH OF RIVER SANITARY DISTRICT NO. 1 AND _____

Type of Insurance: Liability Insurance

THIS IS TO CERTIFY that the following policy has been issued by and below-stated company in conformance with the requirements of Sections 8-1 and 8-2 of the General Provisions of the North of River Sanitary District No. 1 Standard Specifications for Sanitary Sewer System Improvements and is in force at this time.

POLICY NUMBER	EXPIRATION DATE	LIMITS OF LIABILITY In Thousands (000)	
		Occurrence	Aggregate
A. GENERAL LIABILITY			
		Bodily Injury	\$ \$
		Property Damage	\$ \$
		Bodily Injury and Property Damage Combined	\$ \$
		Personal Injury	\$ \$
B. AUTOMOBILE LIABILITY			
		Bodily Injury (Each Person)	\$ \$
		Bodily Injury (Each Occurrence)	\$ \$
		Bodily Injury and Property Damage Combined	\$ \$
C. EXCESS LIABILITY			
		Bodily Injury and Property Damage Combined	\$ \$

The following types of coverage are included in said policies (indicate by "X" in space):

A. GENERAL LIABILITY:

Comprehensive Form	YES _____	NO _____
Premises-Operations	YES _____	NO _____
Explosion and Collapse Hazard	YES _____	NO _____
Underground Hazard	YES _____	NO _____
Products/Completed Operations Hazard	YES _____	NO _____
Contractual Insurance	YES _____	NO _____
Broad Form Property Damage Including Completed Operations	YES _____	NO _____
Independent Contractors	YES _____	NO _____
Personal Injury	YES _____	NO _____

B. AUTOMOBILE LIABILITY

Comprehensive Form Including Loading and Unloading	YES _____	NO _____
Owned	YES _____	NO _____
Hired	YES _____	NO _____
Non-Owned	YES _____	NO _____

C. EXCESS LIABILITY

Umbrella Form	YES _____	NO _____
Other Than Umbrella Form	YES _____	NO _____

This certificate or verification of insurance is not an insurance policy and does not amend, extend, or alter the coverage afforded by the policies listed herein. Notwithstanding any requirement, term, or condition of any contract or other document with respect to which this certificate or verification of insurance may be issued or may pertain, the insurance afforded by the policies described herein is subject to all the terms, exclusions and conditions of such policy.

Insurance Company Agent for Service
of Process in California:

Name

Agency

Street Number

Street Number

City and State

City and State

Telephone Number

Telephone Number

NOTICE:

No substitution or revision to the above certificate form will be accepted. If the insurance called for is provided by more than one insurance company, a separate certificate in the exact above form shall be provided for each insurance company.

Insurers must be authorized to do business and have an agent for service or process in California and have an "A" policyholder's rating and a financial rating of at least Class XI in accordance with the most current Best's Rating.

On this ___ day of _____, 20___, before me personally came _____ to me known, who being duly sworn, did depose and say: that _____ is an authorized representative of the _____ and acknowledged to me that _____ executed the within instrument on behalf of said insurance company.

In witness whereof, I have signed and affixed my official seal on the date in this certificate first above written.

NOTARY PUBLIC

NOTICE

No substitution or revision to the above certificate form will be accepted. If the insurance called for is provided by more than one insurance company, a separate certificate in the exact above form shall be provided for each insurance company.

Insurers must be authorized to do business and have an agent for service or process in California and have an "A" policyholder's rating and a financial rating of at least Class XI in accordance with the most current Best's Rating.

Appendix B– DISTRICT PROCEDURES CHECKLIST

Final Review & Approval of Plans/Specs

- ✓ District reviews submitted final Plans/Specs + Grants of Easements (within 20 working days).
- ✓ Take proposed contract for Sewer Improvement to District.
- ✓ If no corrections → District Board approves at next regular meeting.

Issuance of Construction Permit

- ✓ Developer submits 2 sets of contracts, all fees due, and Guarantee Bonds (if applicable).
- ✓ Developer submits 4 sets of Worker's Comp & Liability Insurance forms (if applicable).
- ✓ District reviews documents within 10 working days; signs and returns contract.

Record Drawings / AutoCAD Files (Tract Development only)

- ✓ Record Drawings electronically in AutoCAD format.
- ✓ Index file and Surveyor's Worksheets sent to NORSD.
- ✓ District reviews and approves.
- ✓ Once all sewer inspections have been completed, owner submits As Builts

Final Acceptance of Work

- ✓ Once all contract requirements have been met, a letter of acceptance is issued to developer.
- ✓ Notice of Acceptance given to property owner, must coincide with contracted party.

Connections to District Sewer System

- ✓ No connections are allowed until Notice of Final Acceptance is issued.
- ✓ Letter of acceptance is the document required that allows the developer to apply for a Permit for sewer connections.
- ✓ Unauthorized non-permitted lateral connections → District may disconnect at Developer's expense and penalties will be assessed.

One-Year Guarantee

- ✓ Owner guarantees all materials, equipment, and workmanship for 1 year after Final Acceptance.
- ✓ If Owner fails to remedy defects → District may correct at Owner's expense.

Giving Notice

- ✓ Notices must be delivered in person or by registered/certified mail (return receipt requested).
- ✓ Address changes must be given in writing.

APPENDIX C – GENERAL TESTING REQUIREMENTS

General Testing	
<p style="text-align: center;"><u>Leakage & Infiltration (All Sewer Types)</u></p> <p>Required for: VCP, PVC, manholes, appurtenances.</p> <p>Water Test: Max leakage = 0.1 gal/min/inch dia/1,000 ft. Air Test: Maintain 4.0 psig · drop to 3.5 psig · measure time to 2.5 psig.</p> <p>Criteria: <i>Must pass either test. If failed, repair or replace pipe.</i></p>	<p style="text-align: center;"><u>CCTV Inspection</u></p> <p>Required for- Final acceptance.</p> <p>Procedure: 360° camera inspection, submit in digital format.</p> <p>Criteria: <i>Must be approved by District.</i></p>
<p style="text-align: center;"><u>Mandrel Test (PVC Pipe)</u></p> <p>Required for: deflection detection, joint offsets, intrusions.</p> <p>Procedure: Rigid mandrel (95% of avg inside diameter).</p> <p>Criteria: <i>No obstruction; correct issues if found.</i></p>	<p style="text-align: center;"><u>Balling and Mirroring (All Pipes)</u></p> <p>Required for: Proper alignment and grade.</p> <p>Procedure: Pass scrubbing ball through pipe, perform mirror inspection of straight and curved sections</p> <p>Criteria- <i>No obstruction; correct issues if found.</i></p>
Manhole Testing	
<p style="text-align: center;"><u>Watertightness</u></p> <p>Required for: Integrity of manhole.</p> <p>Procedure: Fill manhole with water, observe for 1hr for leakage.</p> <p>Criteria: <i>No measurable leakage; repair if detected.</i></p>	<p style="text-align: center;"><u>Chemical Resistant Coating</u></p> <p>Required for: Coating integrity.</p> <p>Material: High-Build Epoxy Type A, B, or C</p> <p>Criteria: Must meet all ASTM standards for flexibility, hardness, abrasion, thickness.</p>
Material Testing	
<p style="text-align: center;"><u>Compaction</u></p> <p>Required for: Stable foundational base of fill materials.</p> <p>Procedure: Pipe zone: 95% relative compaction, above pipe zone: 90% (open field), 95% (street zone)</p> <p>Criteria: <i>Must meet all ASTM standards for moisture density, sand cone, nuclear, Retest failed areas every 25 ft.</i></p>	<p style="text-align: center;"><u>Sand and Aggregate</u></p> <p>Required for: ensure stable foundational base of fill materials.</p> <p>Procedure: Sample material, Perform sieve analysis per ASTM C33, Confirm gradation and cleanliness.</p> <p>Criteria: <i>Free of deleterious materials; meet gradation requirements.</i></p>
<p style="text-align: center;"><u>Concrete</u></p> <p>Required for: Structural components such as vaults, slabs, encasements, manhole bases.</p> <p>Concrete Strength- Class A: 3,000 psi @ 28 days; Class B: 2,500 psi @ 28 days; Class C: 2,000 psi @ 28 days.</p> <p>Criteria: Must meet strength requirements before backfill or load.</p>	

APPENDIX D – REPORTING CRITERIA TO COLLECTIONS

Reporting Criteria

Project Information

Project	
Contractor	
Foreman	
Date	

1. Sewer Installation & Testing

Inspection Task	Contractor Verification (✓)	Notes
Pipe Zone installed per NORSD Standards.		
Manhole base with rebar, cinder blocks, pipe ends w/water stops.		
Bedding (pea gravel to daylight, +6" after inspection).		
Trench zone compaction.		
Compaction report emailed to NORSD.		
Mandrel		
Air test (prior to backfill)		
Video inspection		
Final ball		
Manhole lids inscribed "NORSD"		

2. Documentation & Scheduling

Requirement	Verified (✓)	Notes
Inspection request called in 24 hours in advance		
Required test reports submitted to NORSD		
As-built submittals, survey documentation		
Contractor contact confirmed for field coordination		